

### Vent Material

This unit is approved for installation using 4 x 6-5/8 in co-axial direct vent pipe and accessories manufactured by Simpson Dura-Vent. Follow the installation instructions supplied with the individual venting accessories.

This unit may also be converted to co-linear (2 x 3 in) venting for use in solid-fuel burning fireplaces and chimneys using adapters and accessories—see list below.

### Approved Venting Accessories—Simpson Dura-Vent DV unless otherwise specified

#### Termination Caps

- 46DVA-HC—Standard Co-axial Horizontal
- 46DVA-VC—Standard Co-axial Vertical
- 46DVA-VCH—High Wind Co-axial Vertical
- 46DVA-VCE—Extended Co-axial Vertical
- 46DVA-SNK14—Snorkel, 14" Rise
- 46DVA-SNK36—Snorkel, 36" Rise
- 559CLT—Co-linear Terminal (Valor)

#### DV 45° Elbows

- 46DVA-E45—Galvanized
- 46DVA-E45B—Black

#### DV 90° Elbows

- 46DVA-E90—Galvanized
- 46DVA-E90B—Black

#### Pipes 4" x 6-5/8"

- 46DVA-06—Galvanized, 6" long
- 46DVA-06B—Black, 6" long
- 46DVA-09—Galvanized, 9" long
- 46DVA-09B—Black, 9" long
- 46DVA-12—Galvanized, 12" long
- 46DVA-12B—Black, 12" long
- 46DVA-18—Galvanized, 18" long
- 46DVA-18B—Black, 18" long
- 46DVA-24—Galvanized, 24" long
- 46DVA-24B—Black, 24" long
- 46DVA-36—Galvanized, 36" long
- 46DVA-36B—Black, 36" long
- 46DVA-48—Galvanized, 48" long
- 46DVA-48B—Black, 48" long

#### Flashing

- 46DVA-F6—Roof 0/12–6/12
- 46DVA-F12—Roof 7/12–12/12
- 46DVA-FF—Flat roof
- 559FSK—Flashing (Valor)

### Other accessories

- 46DVA-GCL—Co-axial to Co-linear Adapter
- 46DVA-GK—Co-linear to Co-axial Adapter
- 46DVA-WT—Wall Thimble
- 46DVA-SC—Storm Collar
- 46DVA-DC—Decorative Plate
- 46DVA-CS—Cathedral Ceiling Support
- 46DVA-FS—Ceiling Firestop / Floor Support
- 46DVA-WS—Wall Strap
- 46DVA-VSS—Vinyl Siding Standoff
- 46DVA-ES—Elbow Strap
- 46DVA-WG—Terminal Guard
- 2280—2-ply liner approved to CAN/ULC S635 suitable for venting gas appliances

### Wall Thickness

The appliance vent is suitable for penetrating a combustible wall assembly up to 8 inches in thickness. A non-combustible wall can be of any thickness up to the maximum horizontal run of vent pipe allowed for the particular installation.

### Framing Vent in Combustible Walls & Ceilings

When penetrating through combustible walls and ceilings, frame a minimum of 10 in x 10 in opening and ensure that the insulation is kept clear of the vent pipe using either a wall thimble or an attic insulation shield. Follow the installation instructions supplied with the individual venting components.

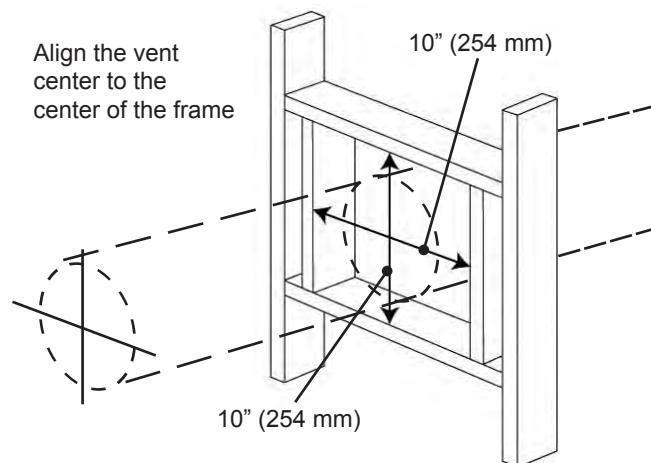

# Co-Axial Venting

## Important Installer Notice – Weather Sealing & Vapor Barriers

It is the installer's responsibility to ensure that vent installations through exterior walls are caulked and weatherproofed in such a manner as to:

- Prevent rain water from entering the wall from the weather side by adequately caulking the outer vent plate to the exterior wall surface.
- Prevent moisture inside the home from penetrating into the wall structure by ensuring the inside wall plate is adequately sealed to the inside vapor barrier.
- Prevent rain water and moisture from entering the walls by sealing the joints between the outer vent tube and the inner and outer wall plates.

We recommend the use of a high quality polyurethane sealant.

## Typical Co-axial Venting Components

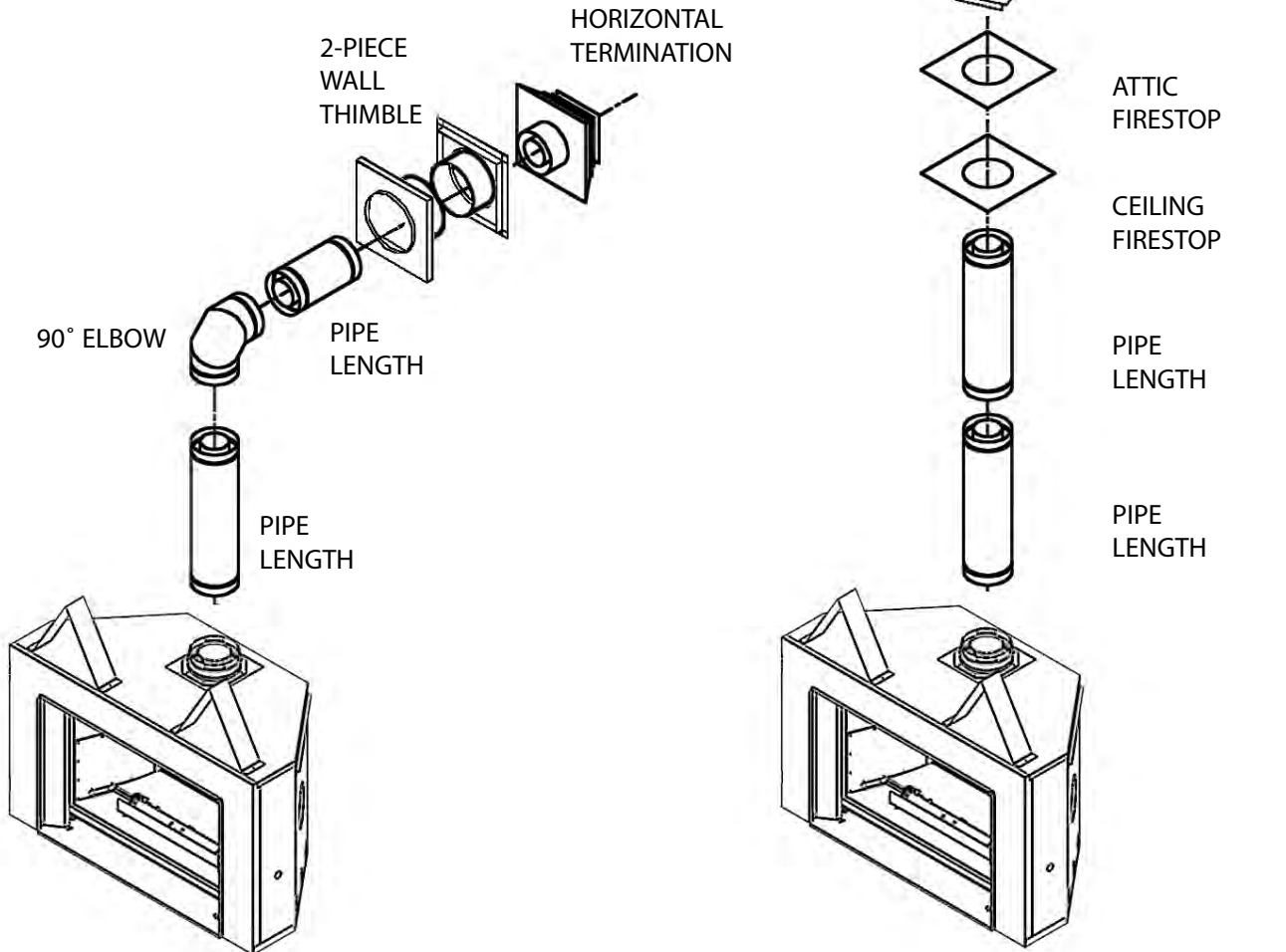

# Co-Axial Venting

## How to Read the Venting Chart

The chart below applies to co-axial roof or wall termination.

1. The total length of the vent pipe cannot exceed 40 feet.
2. The minimum vertical height with roof termination is 6 feet.
3. Any combination of rise and run can be used as long as they are within the allowable limits shown on the chart below.
4. A maximum of 4 x 90 degrees elbows—or equivalent (2 x 45 degrees = 90 degrees)—can be used.

5. Each 90 degrees elbow installed on the horizontal plane is equivalent to a 3 feet horizontal pipe; therefore, 3 feet must be subtracted from allowable horizontal run. (45 degrees elbow is equivalent to 18 inches horizontal pipe.)
6. All horizontal pipe runs must be graded 1/4 inch per foot upwards in the direction of the exhaust flow. The final pipe length, when terminating through the wall may be graded downwards slightly to prevent water migration.
7. A restrictor is required for all installations—see next section.

## Venting Chart

**4 x 90° ELBOWS  
MAXIMUM (or equivalent)**

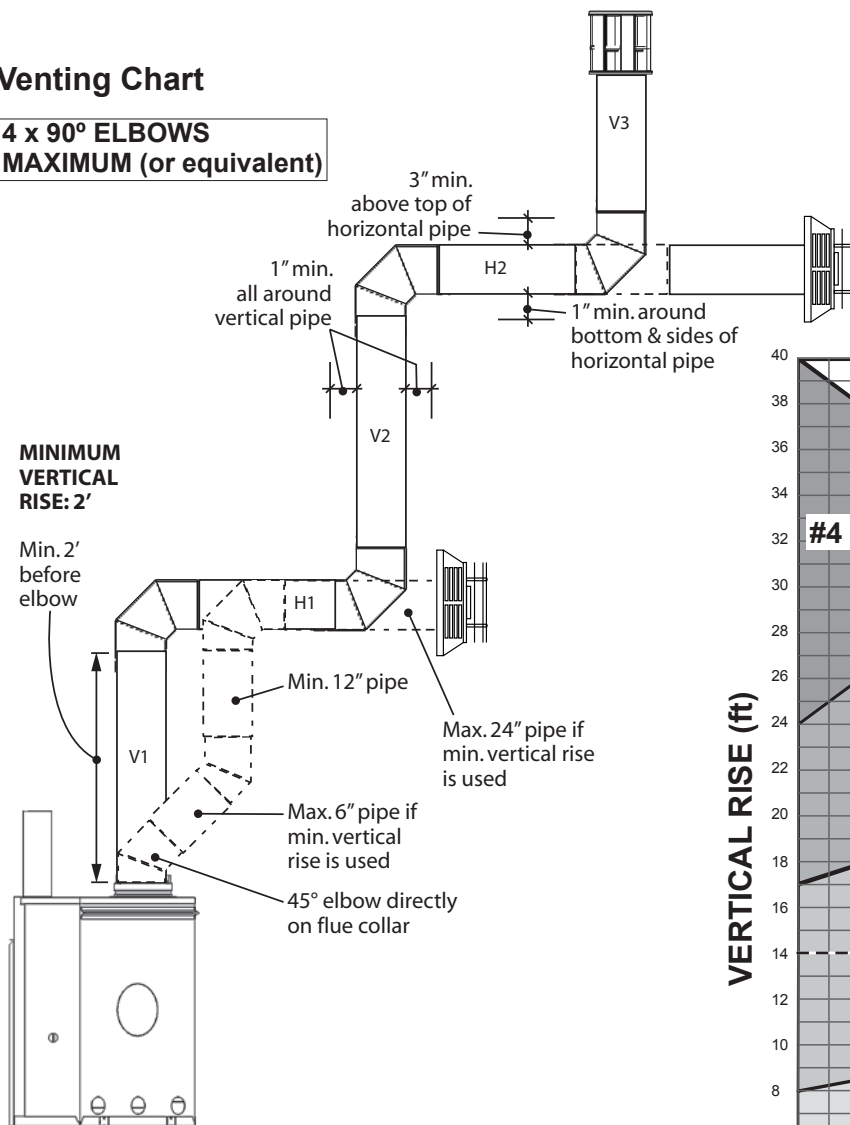

## Allowable Co-Axial Vent Configurations

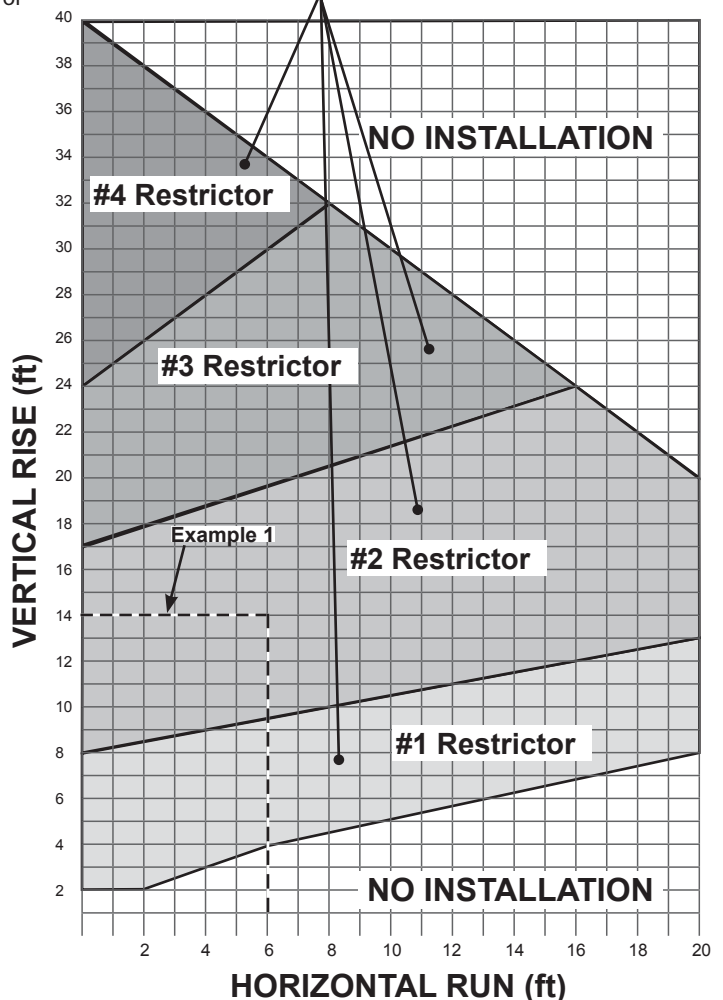

### Example 1

$$V \text{ Value} = V1 (6') + V2 (6') + V3 (2') = 14'$$

$$H \text{ Value} = H1 (3') + H2 (3') = 6'$$

#2 Restrictor position required

# Co-Axial Venting

## Restrictor

**ALL INSTALLATIONS REQUIRE A RESTRICTOR** for improved flame picture and performance. This unit is supplied with a pre-fitted restrictor having four different positions or settings. The level of restriction required depends on the vertical rise in the venting system and, to a lesser degree, the horizontal run and number of elbows.

The amount of restriction is based on laboratory tests. The ideal restrictor position may vary slightly, especially when the vent pipe length is near the limits of the acceptable configurations for each type of restrictor.

The chart on the previous page shows the vent restrictor required relative to the length of the vent pipe.

To set the restrictor position:

1. Establish the required position of the restrictor looking up the venting table on the previous page.
2. Release the screws (2) on each side of the restrictor already installed.
3. Slide the restrictor in the required position.
4. Tighten the screws.

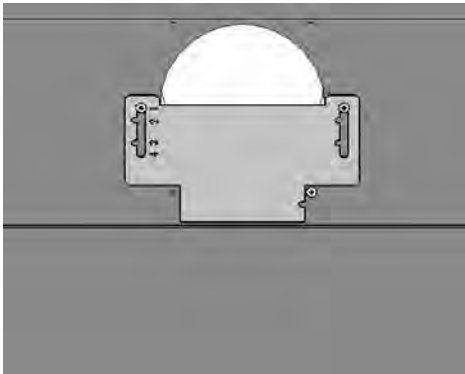
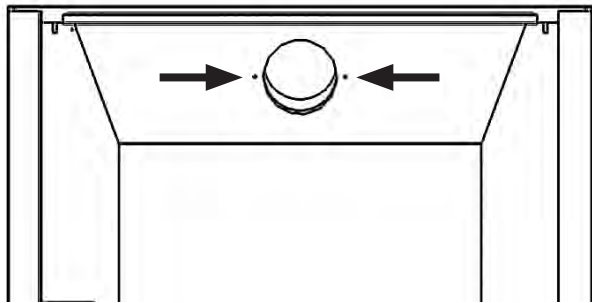

Position #1

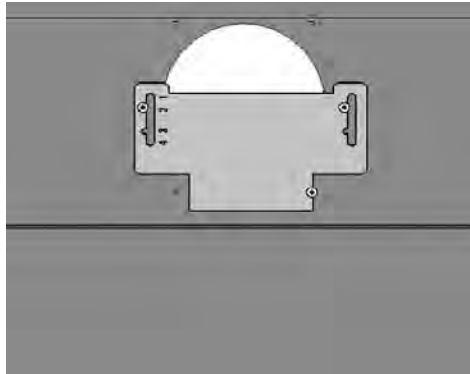

Position #2

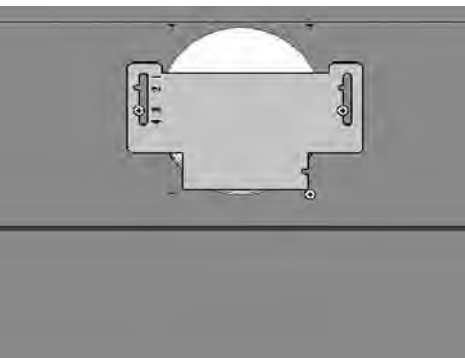

Position #3

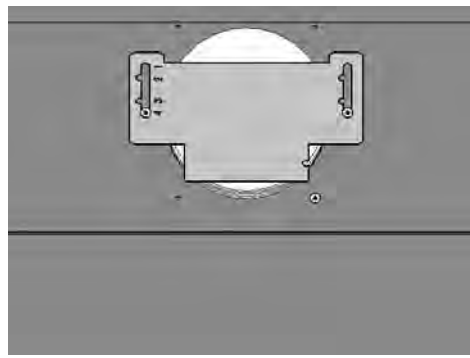

Position #4

# Co-Axial Venting

## Vent Termination

- The vent terminal must be located on an outside wall or through the roof.
- This direct vent appliance is designed to operate when an undisturbed airflow hits the outside vent terminal from any direction.
- The minimum clearances from this terminal that must be maintained when located on an outside wall are shown in the figure below. Any reduction in these clearances could result in a disruption

of the airflow or a safety hazard. Local codes or regulations may require greater clearances.

- The vent terminal must not be recessed into a wall or siding.
- The vent terminal should be positioned where it will not be covered by snowdrifts.
- Sidewall vent terminations within 7' of grade require a terminal guard.

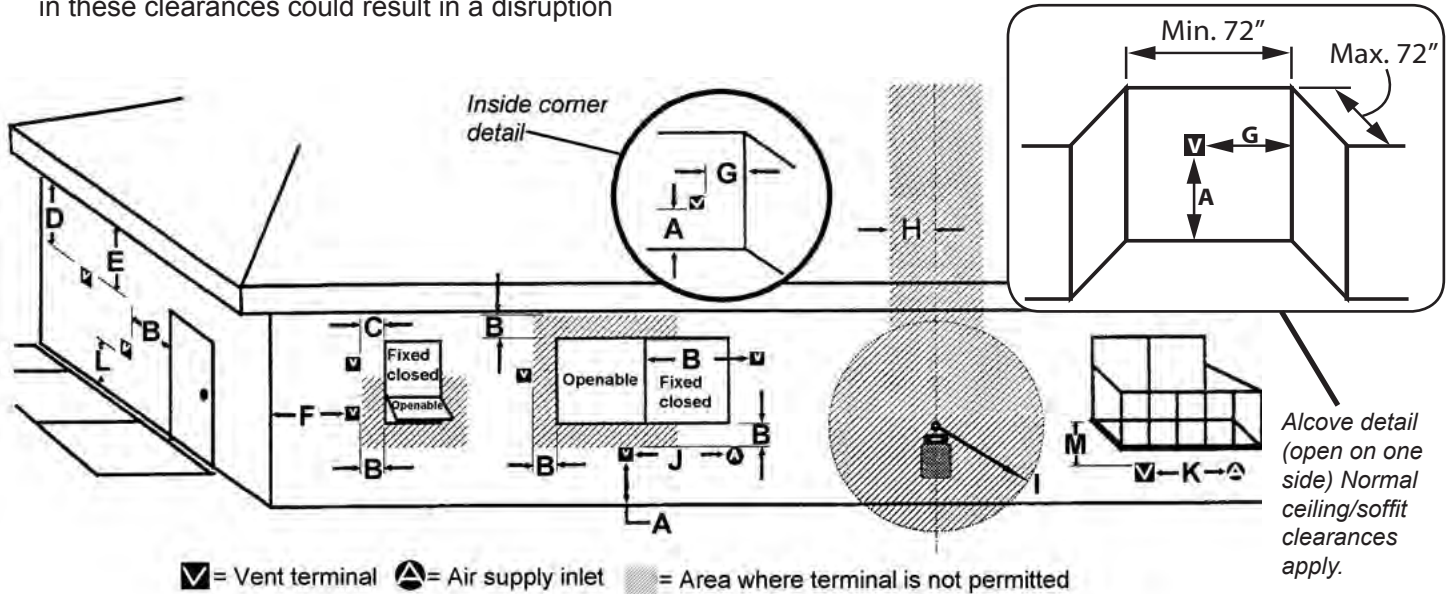

KEY	VENT TERMINAL LOCATIONS - MINIMUM DISTANCES	MINIMUM CLEARANCE	
		Inches	Cm
A	Clearance above grade, verandah, porch, deck or balcony	12	30
B	Clearance to window or door that may be opened	12	30
C	Clearance to permanently closed window (recommended to prevent condensation on window)	12	30
D	Vertical clearance to ventilated soffit located above the terminal within a horizontal distance of 2 feet (60 cm) from the center-line of the terminal	18	46
E	Clearance to unventilated soffit	12	30
F	Clearance to outside corner	12	30
G	Clearance to inside corner	12	30
H	Horizontal clearance to center-line of meter/regulator assembly located within 15 feet (4,6 m) below the terminal	36	90
I	Clearance to service regulator vent outlet	36	90
J	Clearance to non-mechanical air supply inlet to the building or the combustion air inlet to any other appliance	12	30
K	Clearance to a mechanical air supply inlet	72	180
L	Clearance above paved sidewalk or a paved driveway located on public property <b>Note:</b> A vent must not terminate directly above a sidewalk or paved driveway, which is located between two single-family dwellings and serves both dwellings	84	210
M	Clearance under a verandah, porch, deck or balcony Only permitted if veranda, porch, deck or balcony is fully open on a minimum of 2 sides beneath the floor	12	30

Note: Local codes and regulations may require different clearances.

# Co-Axial Venting

## Vertical Vent Termination

Roof Pitch	Minimum "H" (feet)
Flat to 7/12	1'
Over 7/12 to 8/12	1.5'
Over 8/12 to 9/12	2'
Over 9/12 to 10/12	2.5'
Over 10/12 to 11/12	3.25'
Over 11/12 to 12/12	4'
Over 12/12 to 14/12	5'

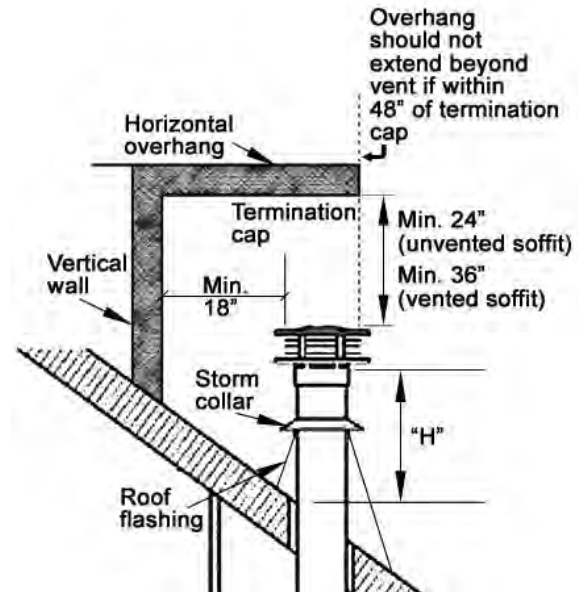

## Co-Linear Venting

### Conversion to Co-Linear Liners using generic Co-Linear Adapters

Co-linear portion of vent system may only be installed within a solid-fuel burning fireplace and chimney. The appliance must not be connected to a chimney flue serving a separate solid-fuel burning appliance. Requires a Co-Axial to Co-Linear appliance Adapter, two lengths of 2-ply 3" dia. flexible chimney liner approved for venting gas appliances, a co-linear termination kit and flashing or a co-linear to co-axial adapter and either a high wind vertical vent terminal cap or a low profile vertical termination. *Firebox top zero clearance stand-offs supplied with the heater are not required for this application.*

### Rules for Co-Linear Venting

- Maximum 40 feet vertical pipe
- Minimum 10 feet vertical
- Maximum offset 8 feet with liners at minimum 45 degrees from horizontal plane
- Restrictor: Use #4 position for all co-linear installations—refer to page 17 for restrictor positioning.

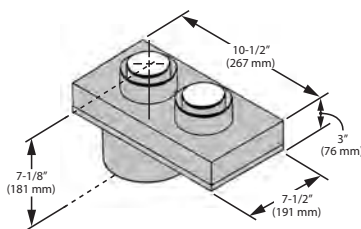

Dura-Vent #46DVA-GCL  
Co-Axial to Co-Linear Adapter

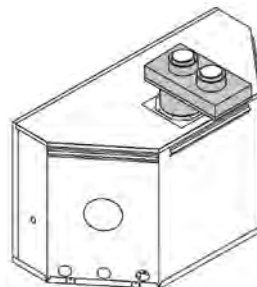

Vogue with co-linear adapter

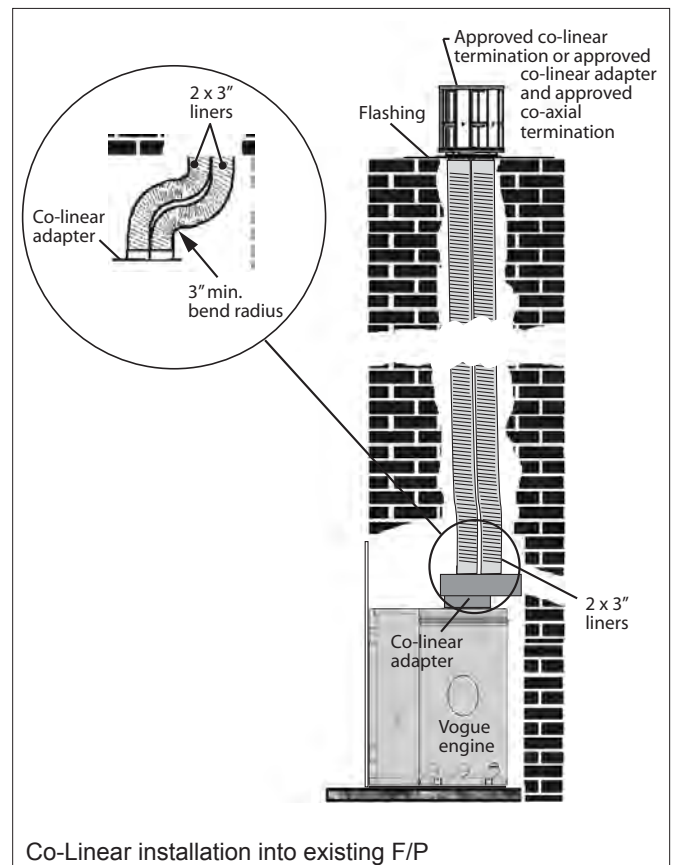

Co-Linear installation into existing F/P

# Co-Linear Venting

## Co-linear terminal configurations

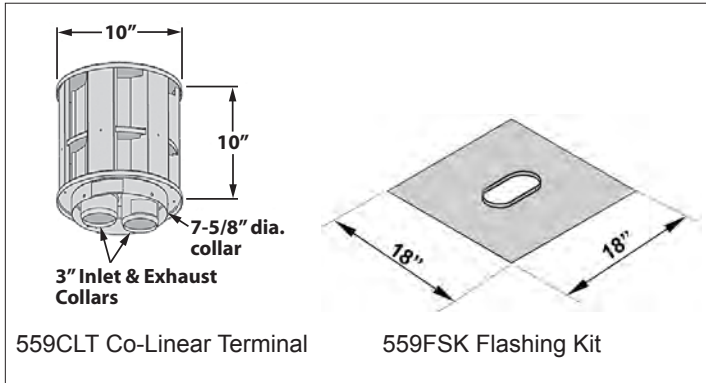

## Alternate to 559CLT/559FSK Conversion

