

valor® L2 1700K

December 2019
1/3

Cement Board

Material Specifications

Non-Combustible

Material which will not ignite and burn. Such materials are those consisting entirely of steel, iron, brick, tile, concrete, slate, glass or plasters, or any combination thereof.

Materials that are reported as passing ASTM E 136, Standard Test Method for Behavior of Materials in a Vertical Tube Furnace at 750°C shall be considered non-combustible materials.

Combustible

Materials made of or surfaced with wood, compressed paper, plant fibers, plastics, or other material that can ignite and burn, whether flame proofed or not, or plastered or unplastered shall be considered combustible materials.

Non-Combustible Cement Board

The L2 Linear fireplace requires a 1/2" (13 mm) thick non-combustible cement board to be used as a wall surface immediately surrounding the unit's opening—see diagram for minimum coverage.

Extending the cement board well beyond the minimum shown will help avoid cracking due to differential expansion of materials.

Pre-drill cement board with oversized holes and do not over-tighten screws to avoid cracking due to heat expansion.

Standard gypsum wall board may be used beyond the perimeter of the cement board.

| inches [mm] | With 1750 or 1775 trims | with 1730CIK kit |
|-------------|-------------------------|---------------------|
| A | Min. 20-1/2 [521] | Min. 20-1/8 [511] |
| B | 14-3/4 [375] | 15-13/16 [401] |
| C | Min. 9-1/4 [235] | Min. 8-9/16 [218] |
| D | Min. 5 [127] | Min. 4-1/2 [114] |
| E | Min. 50 [1270] | Min. 51-1/16 [1296] |

Minimal coverage area of non-combustible cement board.
Any wall finish applied to shaded area must be non-combustible.

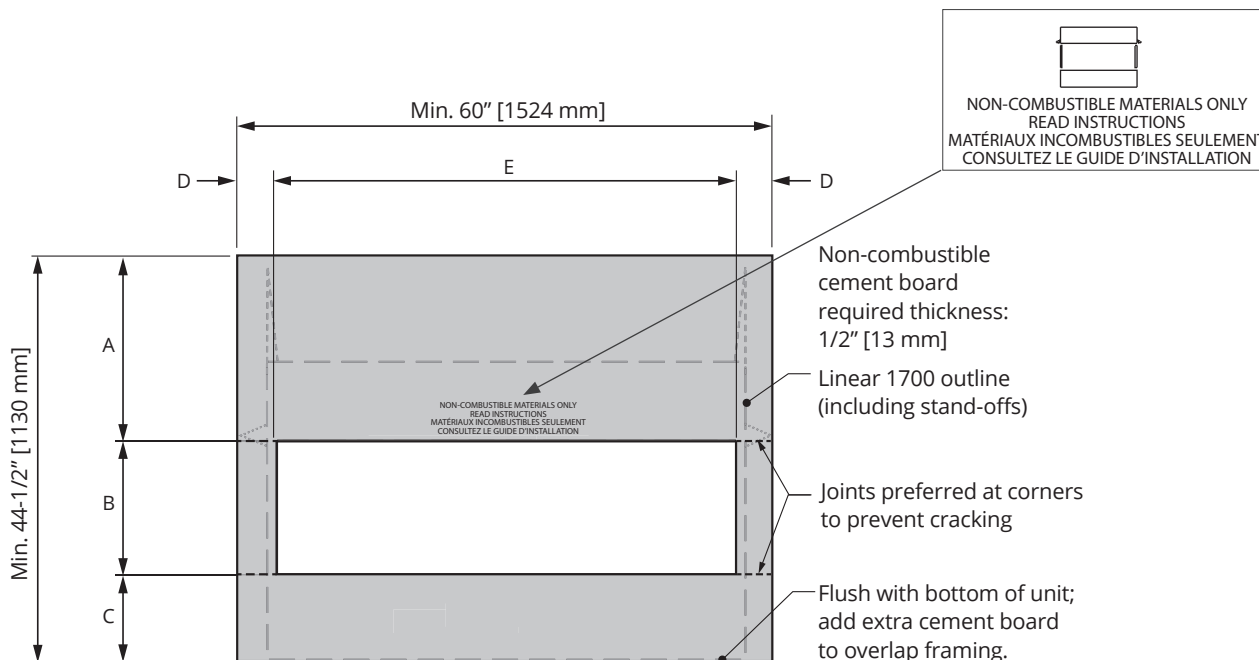

Valor® L2 1700K

December 2019
2/3

Wall Finish — Trims

Non-Combustible Finishing Over Cement Board

Additional non-combustible material such as tile, etc., may be applied over top of the cement board or you may choose to leave it finished clean with no tile, etc.

Be aware that a trim is always required. Finish **should not cover** the trims.

1775 and 1750 Trims

Only the 1775 and 1750 style trims will accept tile, etc. tucked behind them (up to 5/8" thick for the 1775 and up to 1 inch thick for the 1750).

1730 Trim

1730 trim must be installed **BEFORE** cement board. Cement board and finishes are applied to the perimeter of the trim frame. Cement board and finished **CANNOT** be tucked under this trim.

Wider trim (1750) can adjust up to 1" forward of surface of cement board. Cement board tucks behind trim.

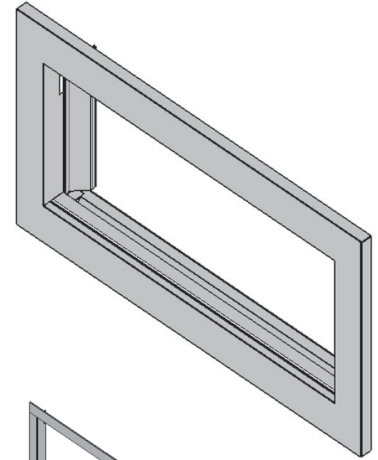

Narrow trim (1775) can adjust up to 5/8" forward of surface of cement board. Cement board tucks behind trim.

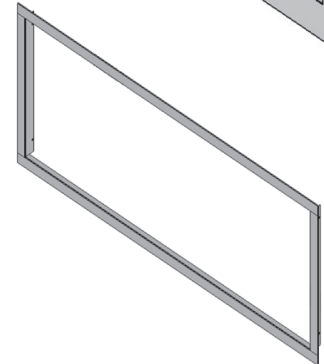

Clean Installation Kit 1730CIK requires HeatShift. Cement board finishes up to perimeter of frame. **Must install BEFORE cement board.**

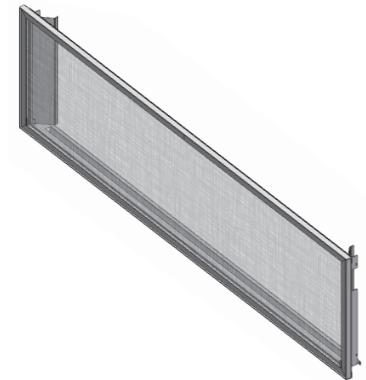

Wall Finish — Avoid Cracking

Avoiding Cracking Wall Finishes

We recommend installing the optional HeatShift System to reduce the wall temperatures and minimize the possibility of cracking wall finishes.

WARNING

HeatShift System MUST be installed on this appliance when using 1730CIK—Clean Installation Kit.

If a clean finish with no tile, etc. is desired, joints in the cement board and the transition to gypsum board will require special attention if future cracking is to be controlled. Be aware that temperatures on the non-combustible wall surface above the appliance can exceed 200°F (93°C).

Below are some tips on how to best avoid any cracking:

- Allow materials to dry thoroughly before finishing the wall. Cement board has the ability to absorb up to 30 percent of its weight in water and may shrink as much as 1/8" over a 48" length when drying from a saturated condition. Running the fireplace for an extended period before final finishing will help drive out moisture.

- Always pre-drill screw holes through cement board and use screws specific for material used.
- Always use mesh tape over joints.
- Always stagger joints in wall board.
- Behind joints, double up studs or use studs "on the flat" to add extra support to the joint. Adhesive on the backside of wall board behind any joints can help control differential movement.
- Use multiple, thinner coats of joint compound and allow to dry thoroughly between coats.
- Ensure framing materials are dry.
- After finishing the wall, introduce heat gradually to slowly dry any excess moisture rather than drying too fast.
- Avoid notching cement board or tiles around corners of window opening and instead provide a joint that intersects the corner.
- Avoid using large one-piece slab of material with a cut-out in the middle as a surround for the fireplace. Expansion above the opening will cause cracking at inside corners. Provide a joint that intersects the inside corner to avoid cracking.

