



#748 CTK / 749 DTK

4 – Sided Trim Kits for G3 Inserts

INSTALLATION INSTRUCTIONS

Sept. 2002

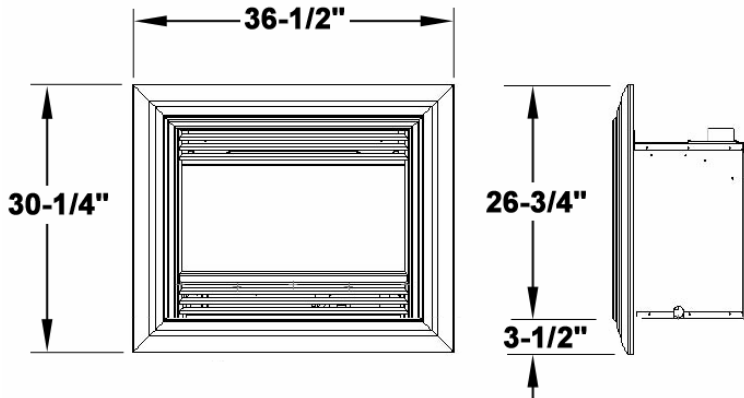

Front View

Side View

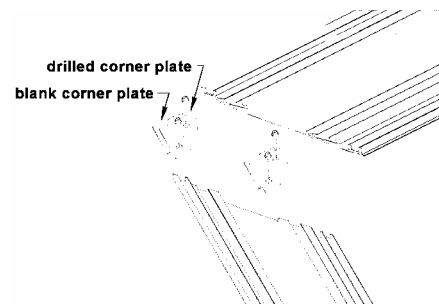

Step 1

Slide the corner connection plates into the extruded channels of the sides and top trim pieces. Butt the mitered corners together. Fit the grub screws and tighten while maintaining the fit of the miter.

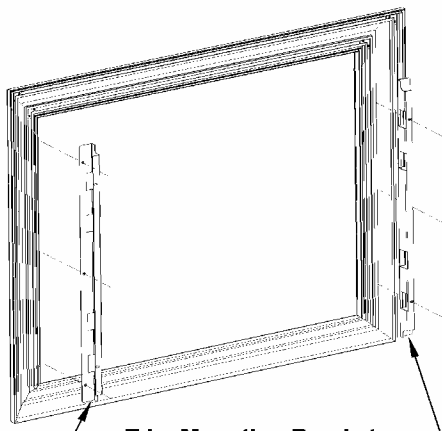

Trim Mounting Brackets
(supplied with heater)
Install bottom of bracket flush
to inside corner of extruded trim.

Step 2

Attach the 2 trim mounting brackets to the side trim pieces with 3 screws for each side. The brackets should be flush at the bottom as indicated

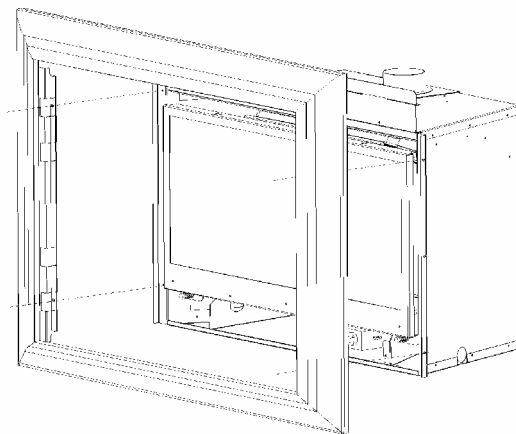

Manufactured and distributed in Western Canada and USA by

Miles Industries Ltd.

829 West Third Street, North Vancouver B.C, CANADA, V7P 3K7

Ph. (604) 984-3496 Fax (604) 984-0246