



Valor

Legend stove



Models

936XN (Natural Gas)

936XP (Propane)

FREESTANDING DIRECT VENT GAS FIREPLACE HEATER

WARNING: If the information in this manual is not followed exactly, a fire or explosion may result causing property damage, personal injury or loss of life

- Do not store or use gasoline or other flammable vapors and liquids in the vicinity of this or any other appliance.
- **WHAT TO DO IF YOU SMELL GAS**
 - Do not try to light any appliance.
 - Do not touch any electrical switch; do not use any phone in your building.
 - Immediately call your gas supplier from a neighbor's phone. Follow the gas supplier's instructions.
 - If you cannot reach your gas supplier, call the fire department.
- Installation and service must be performed by a qualified installer, service agency or the gas supplier.

INSTALLATION AND OWNER'S MANUAL

For Pedestal base with
Contemporary front
or

Legs with Traditional front

*Please read this manual
before installing and
operating.*

This appliance may be installed permanently located, manufactured (mobile) home, where not prohibited by local codes.

This appliance is only for use with the type of gas indicated on the rating plate. This appliance is not convertible for use with other gases, unless a certified

This appliance is a domestic room heating appliance. It must not be used for any other purpose such as drying clothes etc.

CONTENTS

	Page
Safety information	3
Installation options	4
General data	4
Location in room	5
Vent location	5
Supply gas	8
Pack contents	8
Installing	
• Appliance preparation.....	8
• Vent opening preparation.....	9
• Gas supply installation.....	10
• Base & main appliance installation.....	10
• Pedestal base	10
• Base with legs	11
• Vent unit installation	12
• Gas line connection to appliance.....	13
• Gas system check.....	14
• Pressure relief system check.....	14
• Aeration setting check	14
• Ceramic fuel bed assembly.....	15
• Controls operation check.....	16
• Aeration adjustment	16
• Facia installation.....	16
• Final installation check.....	16
Owner's information	
• General operating procedure.....	18
• Lighting with a long match	18
• Cleaning	18
• Visual checks	18
• Servicing	18
• Lighting instructions.....	19

SAFETY INFORMATION

Due to high temperatures, the appliance should be located out of traffic and away from furniture and draperies.

Children and adults should be alerted to the hazards of high surface temperatures and should stay away to avoid burns or clothing ignition.

Young children should be carefully supervised when they are in the same room as the appliance.

Clothing or other flammable material should not be placed on or near the appliance.

The glass and front frame must be put back in place prior to operating the appliance if they have been removed for servicing or cleaning.

Never operate with broken or damaged window glass.

WARNING: Do not operate the appliance with the glass front removed, cracked or broken. Replacement of the glass should be done by a licensed or qualified service person. (The whole window unit may be temporarily removed by the owner for cleaning the interior of the firebox, etc). Only the authorised Valor replacement window unit listed in the repair parts booklet must be fitted – never use substitutes. If the glass is damaged search inside and adjacent to the appliance for any glass fragments.

This appliance should be installed and repaired by a qualified service person.

The appliance should be inspected before use and at least annually by a professional service person. More frequent cleaning may be required due to excessive lint from carpeting, bedding material, etc. It is imperative that control compartments, burners and circulating air passageways of the appliance are kept clean.

Keep curtains, clothing, furniture and other flammable materials a safe distance from all parts of the appliance and its vent system.

Keep the appliance area well clear and free from combustible materials, gasoline and other flammable vapors and liquids.

Never attempt to burn paper or any other material in the appliance.

Keep the base of the appliance clear to prevent obstruction of air flow to the appliance. If fitted with a pedestal base, make sure that the grill at back is not obstructed. If fitted with legs, make sure there is no obstruction between the legs.

INTERRUPTION OF GAS SUPPLY; If ever there is a break in the flow of gas through the supply system to the appliance (For example, for repair work in the supply system either inside or outside your property), we recommend that the window unit is removed before lighting the pilot. This will allow any air which has become trapped in the supply piping to escape without building up in the firebox before the pilot will light. Wait until the pilot flame is stable before refitting the window but refit it before turning the control to any position other than pilot ignition. Details of how to remove the window are given in the preparation for installation section of this manual.

The vent terminal on the outside wall must be kept free from obstructions. The terminal is hot during operation and requires a guard (Part #235) if it is accessible to any person. No objects should be placed within 2 feet (60cm) of the vent terminal.

During extreme weather conditions ensure that the vent outlet is free from ice and snow before attempting to light.

Do not use this appliance if any part has been under water. Immediately call a qualified service technician to inspect the appliance and to replace any part of the control system and any gas control which has been under water.

NOTE

When operating your new stove for the first time, some vapors may be released which may cause a slight odor and could possibly set off any smoke detection alarms in the immediate vicinity. These vapors are quite normal on new appliances. They are totally harmless and will disappear after a few hours use.

1. OPTIONS

The following options are available for this appliance:
#710 CFK Circulating fan kit (For pedestal base only).

Operated by a variable speed controller, it is designed to boost the natural convection process through the stove. It may be fitted before the stove is installed or retrofitted at a later date.

#905 VEK

Vent extension kit

Designed to give a greater range of venting configurations. See venting graph figure 1 for the available configurations. Use of these kits will allow the stove to be sited in a basement provided that the terminal is above ground.

#925HACK

High altitude conversion kit. (For 936XN only)

Required for installations between 2000ft and 4500ft. Consists of an exchange regulator and associated connectors.

2. GENERAL

These appliances are certified by International Approval Services for use in Canada and the USA. The appliance are for installation directly venting through an outside wall. The appliances are for use only with the type of gas indicated on the rating plate. The appliances comply with CGA P.4.1, Testing method for measuring annual fireplace efficiencies.

The installation must conform with local codes or, in the absence of local codes, with the National Fuel Gas Code, ANSI Z223.1 or the Canadian installation code CAN/CGA-149. Only qualified licensed or trained personnel should install the appliance.

2.1 Rating plate

The rating plate is located inside the control compartment door.

2.2 Rates (Btu/h)

	Altitude (Ft)*	936 XN		936 XP	
		Max.	Min.	Max.	Min.
Input	0-2000	27,000	7,800	20,500	13,000
	2000-4500	23,700	7,200	-	-
Output	0-2000	20,500	5,700	15,600	9,700
	2000-4500	18,000	5,250	-	-

*Altitudes above 2000ft require conversion kit #925HACK

2.3 Pressures (in. w.c.)

	936 XN				936 XP	
	0-2000(Ft)		2000-4500(Ft)		0-2000(Ft)	
	Max	Min	Max	Min	Max	Min
Supply - Upstream of Regulator	10.5	5.0	10.5	5.0	14.0	11.0
Manifold - Tapping on thermostat (Appliance full on)	3.7	3.3	3.2*	2.8*	9.5	9.1

*With conversion kit #925HACK

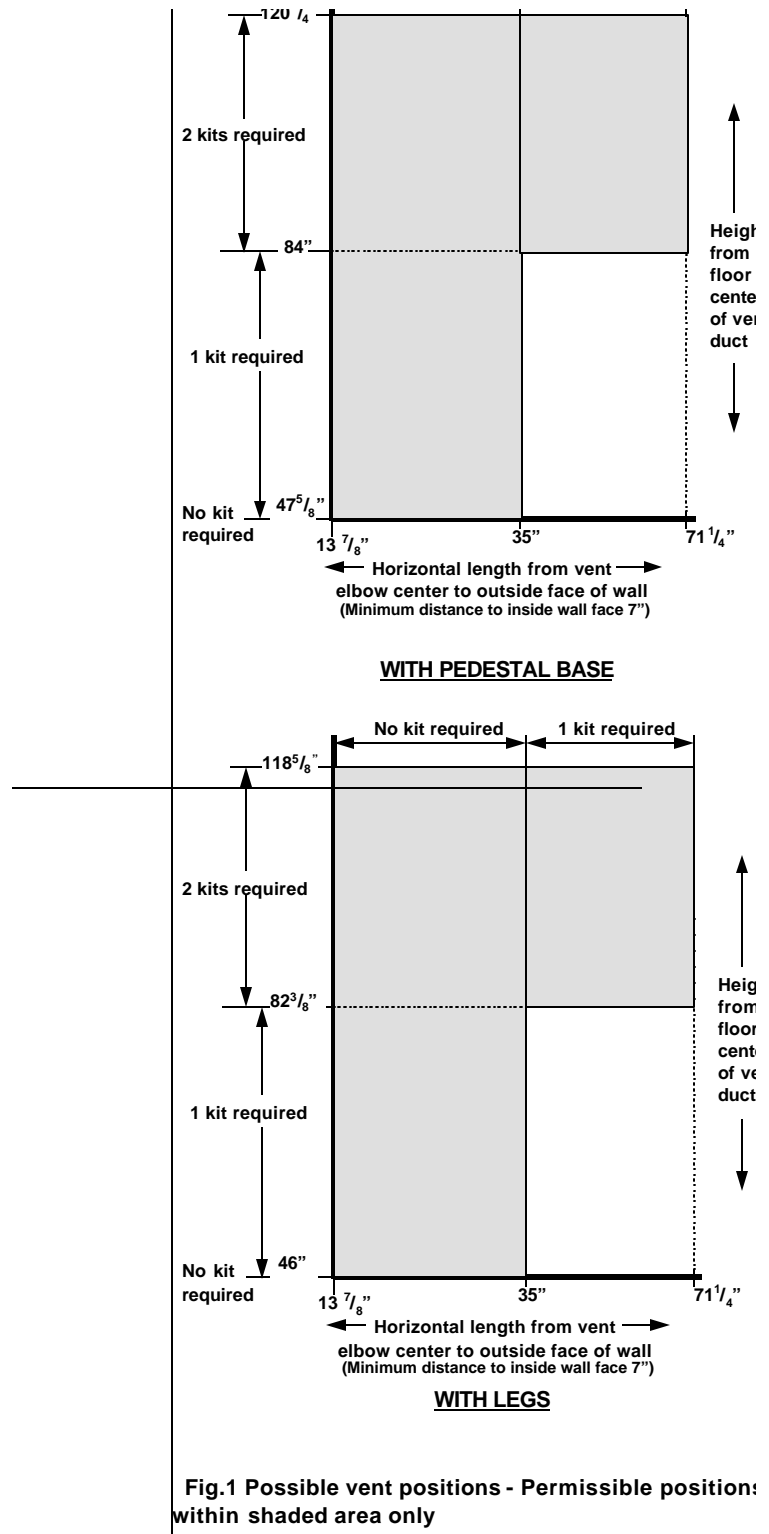

Fig.1 Possible vent positions - Permissible position: within shaded area only

2.4 Orifice data

For verification only. Do not attempt to drill or otherwise modify appliance input.

Model	Orifice	Type	No.of Holes	Diameter (ins.)
936 XN	Pilot	Amal 40	1	0.022
	Front	Cat.18-340	7	0.025
	Rear	Cat.18-380	7	0.027
936 XP	Pilot	Cat.960-10	1	0.01
	Front	Cat.960-110	1	0.035
	Rear	Cat.960-130	1	0.038

3. LOCATION IN THE ROOM

Combustible materials inside the room must not be closer than the dimensions shown in figure 2.

The floor construction should allow the stove to be screwed to the floor. If the stove is to be installed directly on any combustible material other than wood flooring, it must be installed on a metal or wood panel extending the full width and depth of the appliance.

4. VENT LOCATION

- 4.1 The vent terminal must be located on an outside wall.
- 4.2 The vent unit is suitable for wall thicknesses between 3" and 24½". If a vent extension is used horizontally, this can be inserted in the wall allowing for wall thicknesses up to 60¾". See figure 1 for limitations on use of horizontal extension.
- 4.3 The vent clearance hole required in the wall is 8³/₈" diameter.
- 4.4 The stove is supplied with a vent unit including a 90° elbow. This requires the center of the vent hole to be 47⁵/₈" above bottom of the appliance if installed with a pedestal base or 46" above the bottom of the appliance if installed with legs. ***This height must not be reduced by cutting the vertical portion of the elbow duct.***
- 4.5 The 90° elbow can be rotated to allow the horizontal run of the duct to be at any angle relative to the appliance.
- 4.6 Do not attempt to use any vent material other than that supplied with this appliance or kit #905VEK.
- 4.7 This direct vent appliance is designed to operate when an undisturbed air flow hits the outside vent terminal from any direction. The minimum clearances from this terminal which must be maintained are shown in figure 3. Any reduction in these clearances could result in a disruption of the air flow or a safety hazard. Local codes or regulations may require greater clearances.
- 4.8 The terminal, when installed with the vent shield tube and wall plates, is suitable for mounting on wood or vinyl siding without requiring additional shielding. The vent shield tube supplied is suitable for wall thicknesses up to 24½". A custom made shield should be made for thicker walls.
- 4.9 The slots in the vent terminal must not be recessed into a wall or siding.
- 4.10 The vent terminal should be positioned where it will not be covered by any snowdrifts.
- 4.11 **Warning:** If the outside vent terminal is located where it will be accessible to any person, a guard must be fitted over the terminal to prevent damage and to prevent it being touched.
The vent terminal becomes very hot when the appliance is in use and can cause burns. A special guard designed for this appliance is available from your supplier - Ask for Valor part #235 (See figure 4).

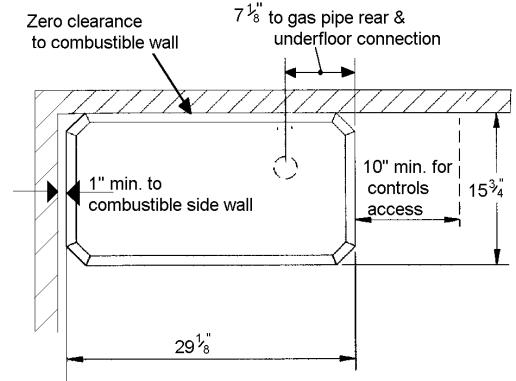
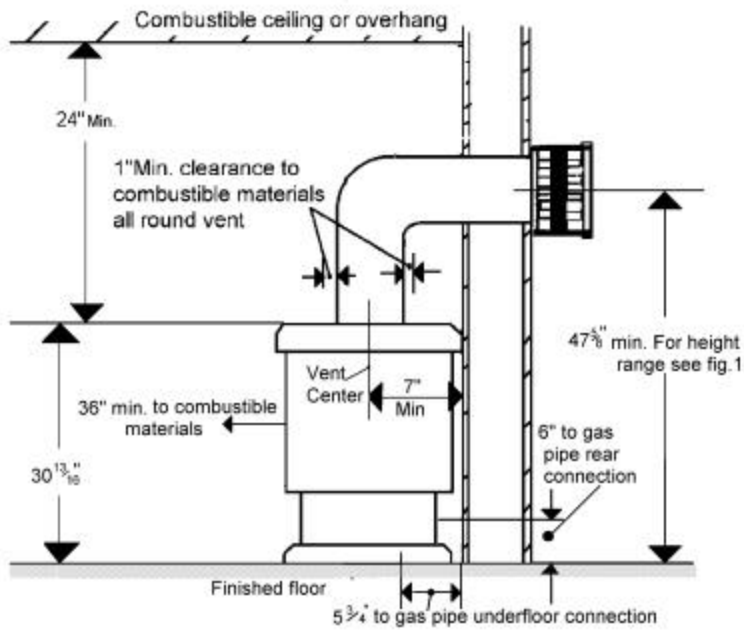

WITH PLINTH

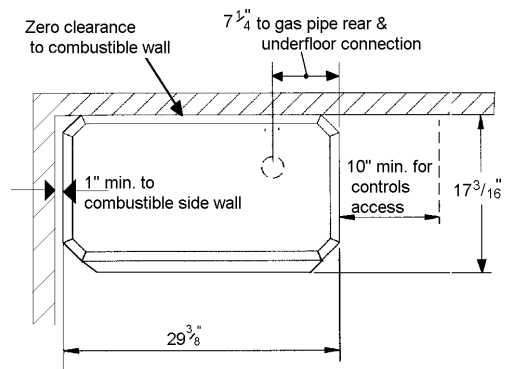
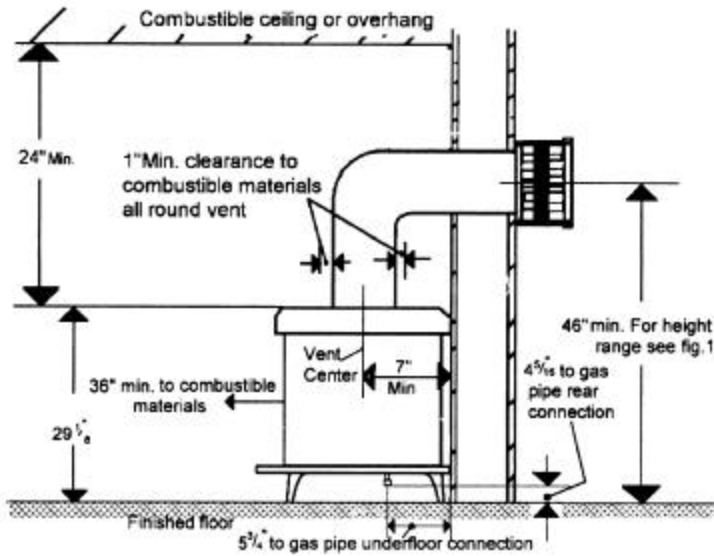

WITH LEGS

Fig.2 Dimensions & clearances

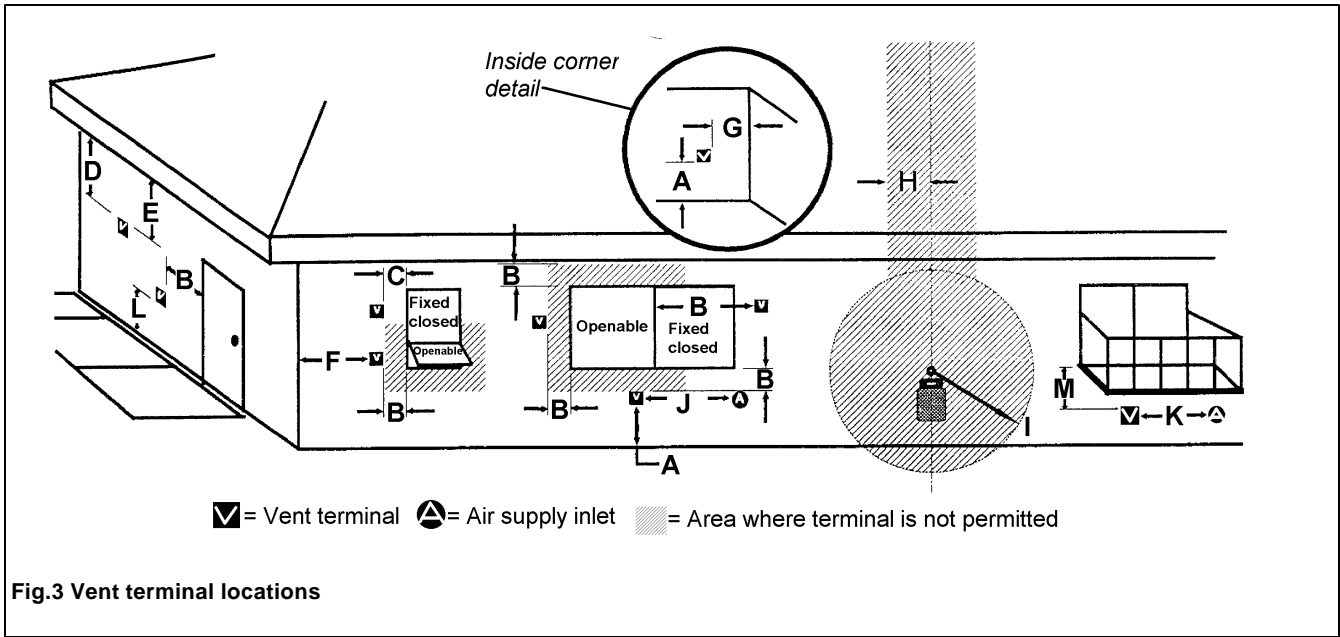

Fig.3 Vent terminal locations

KEY	VENT TERMINAL LOCATIONS - MINIMUM DISTANCES <i>See figure 3</i>	MINIMUM CLEARANCE	
		Ins	cms
A	Clearance above grade, verandah, porch, deck or canopy	12	30
B	Clearance to window or door that may be opened	12	30
C	Clearance to permanently closed window (recommended to prevent condensation on window)	12	30
D	Vertical distance to ventilated soffit located above the terminal within a horizontal distance 2 feet (60cm)	18	46
E	Clearance to unventilated soffit	12	30
F	Clearance to outside corner	12	30
G	Clearance to inside corner	12	30
H	Horizontal clearance to center-line of meter/regulator assembly located below the terminal	36	90
I	Clearance to service regulator vent outlet	72	180
J	Clearance to non-mechanical air supply inlet to the building or the combustion air inlet to any other appliance	12	30
K	Clearance to a mechanical air supply inlet	72	180
L	Clearance above paved sidewalk or a paved driveway located on public property. Note: A vent must not terminate directly above a sidewalk or paved driveway which is located between two single family dwellings and serves both dwellings.	84	210
M	Clearance under a verandah, porch, deck or balcony	12	30

Note: Local codes and regulations may require different clearances.

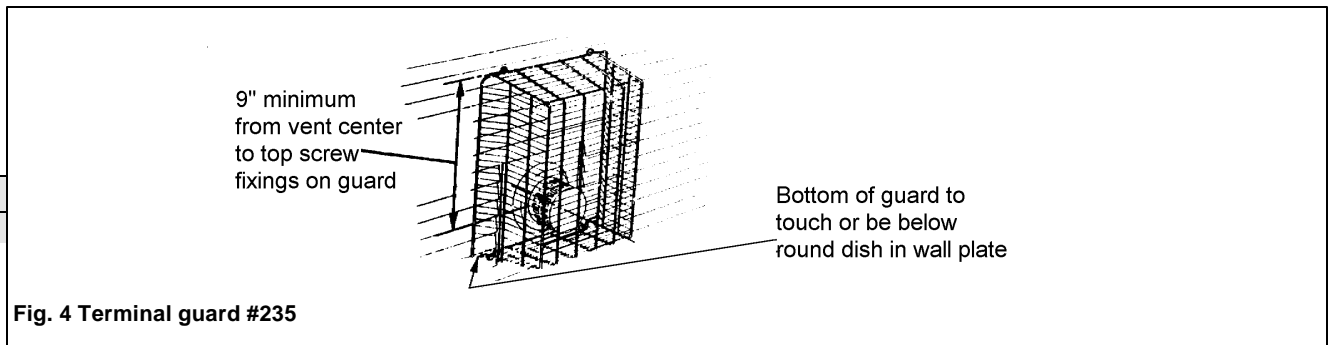

Fig. 4 Terminal guard #235

4. SUPPLY GAS

The supply connection is $\frac{3}{8}$ "NPT. Openings for the gas supply are provided for rear or under-floor connection (see figure 2).

5. PACK CONTENTS

The complete appliance is contained in three packs. One of the alternative base support and front designs will be included - either pedestal with contemporary facia or Legs with traditional facia (See pack 2).

Pack 1 - Main appliance unit contains:-

- 1 Main appliance fitted with window.
- 4 Ceramic logs.
- 1 Pair ceramic firebox side walls.
- 1 Ceramic firebox back wall.
- 1 Decorative vent collar for appliance top.
- 1 Decorative vent collar for wall plate.
- 1 Wall plate with brackets.
- 1 Wall plate without brackets.
- 1 Gas supply inlet pipe.
- 1 Gas supply inlet elbow.
- 1 Exhaust port cover
- 8 Wall plugs (for wall plates).
- 8 Wood screws (for wall plates).

Pack 2 - Pedestal and contemporary facia alternative contains:-

- 1 Pedestal unit.
- 1 Contemporary design front facia unit.
- 1 Ashlip unit.
- 4 #8 tapping screws (for fixing ashlip).
- 4 Machine screws (for fixing pedestal to main appliance).
- 2 Wood screws (for floor fixing).
- 2 Plugs (for floor fixing).

or

Pack 2 - Legs and traditional facia alternative contains:-

- 1 Base & legs unit.
- 1 Traditional design front facia unit.
- 1 Door retaining bracket.
- 1 Window frame top cover.
- 2 #10 tapping screws (for door retaining bracket).
- 4 Machine screws (for fixing base & leg unit to main appliance).
- 2 Wood screws (for floor fixing).
- 2 Plugs (for floor fixing).

Pack 3 - Vent unit contains:-

- 1 90° elbow vent.
- 1 Vent terminal unit.
- 1 Styrofoam support (for vent tube cutting).
- 4 #6 tapping screws (for vent securing).
- 1 Length of vent sealing tape.
- 1 Masking collar (for vent joint).
- 2 #8 tapping screws (for masking collar).
- 1 Outer vent shield.
- 7 #10 nuts & screws (for outer vent shield).

Take care when removing the contents from the packaging to prevent damage. Check that all the contents are in the packs and are undamaged.

6. APPLIANCE PREPARATION

6.1 Remove the window & logs (see figure 5)

6.1.1 Natural Gas Appliances: Detach the window unit by removing the 8 knurled screws ("A") and knurled nut ("B") holding the sides and bottom of the window frame.

LP Appliances: Detach the window unit by removing the 7 spring loaded screws holding the sides and bottom of the window frame.

6.1.2 Lift the window unit up and forwards to unhook the top. Put the window in a safe place.

6.1.3 Take the ceramic logs out of the firebox and store safely.

6.2 Check ignition electrode spark (see figure 6)

The pilot burner and electrode are at the right side of the firebox.

Open the control access door. Turn the gas control knob (the right hand knob) counterclockwise to "Ign". While turning pilot ignition sparks should be activated twice. Check that the sparks are produced at the pilot burner.

If no sparks are produced, check that the wiring is secure and that the spark gap is 3.5 ± 0.5 mm.

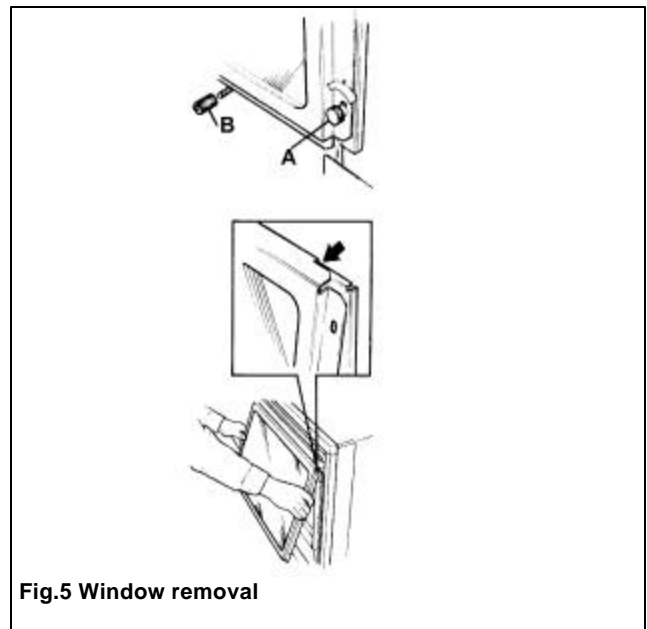

Fig.5 Window removal

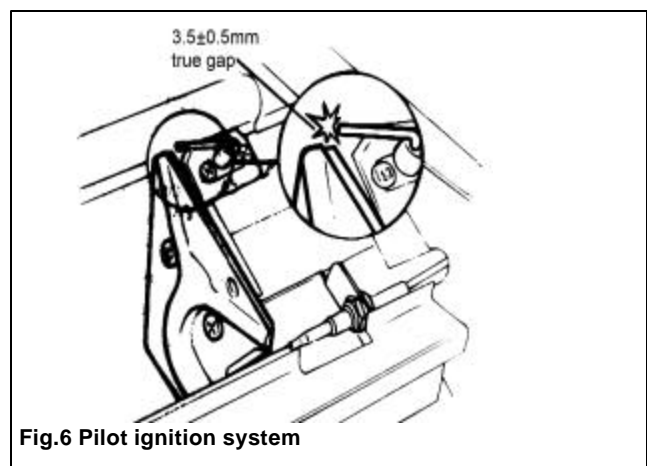

Fig.6 Pilot ignition system

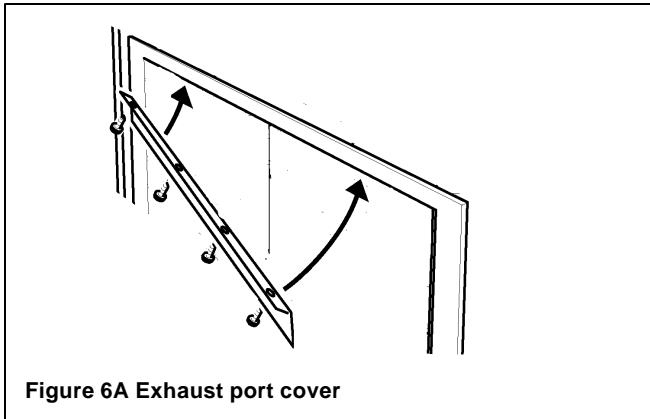

Figure 6A Exhaust port cover

6.3 Fit exhaust port cover (see figure 6A)

Remove four screws from under the top of the firebox. Fit the exhaust port cover and secure with the four screws.

7. VENT OPENING PREPARATION

Important:

This appliance is supplied with a vent unit requiring the center of the vent hole to be $47\frac{5}{8}$ " above the bottom of the appliance if installed with a pedestal base or 46" above the bottom of the appliance if installed with legs. This height must not be reduced by cutting the vertical portion of the elbow duct. For higher vent openings, one or two optional vent extension kits #905VEK must be used - See venting graph figure 1 for the allowable range of heights and number of extensions required. Before cutting the vent opening in the wall, make sure that the installed distance to the bottom of the appliance is known. Once the vent opening in the wall is cut it will not be possible to alter the position of the appliance without re-cutting the wall.

- 7.1 Place dust sheets on the floor and over any furnishings, etc. in the vicinity.
- 7.2 Mark the center of the vent hole in the wall.
- 7.3 Cut $8\frac{3}{8}$ " diameter vent hole through the wall making sure that it is straight and level.
- 7.4 Place the wall plate with brackets against the inside face of the wall with the dished projection seated inside the hole in the wall and the brackets at the sides.
- 7.5 Mark the wall plate fixing holes. Remove the plate.
- 7.6 Drill the plate fixing holes in the wall. Insert wall plugs if necessary.
- 7.7 Replace the plate in the wall. Fix the plate to the wall with four woodscrews.
- 7.8 Measure the total wall depth from its outside surface to the finished surface in the room.
- 7.9 Flatten the outer vent shield tube (*For walls thicker than $2\frac{1}{2}$ " a custom shield should be made*). The tube is supplied coiled around the vent terminal unit. Cut the tube exactly to the total wall depth. Make sure that the cutting line is at least 1" away from the nearest bolt hole (see figure 8).

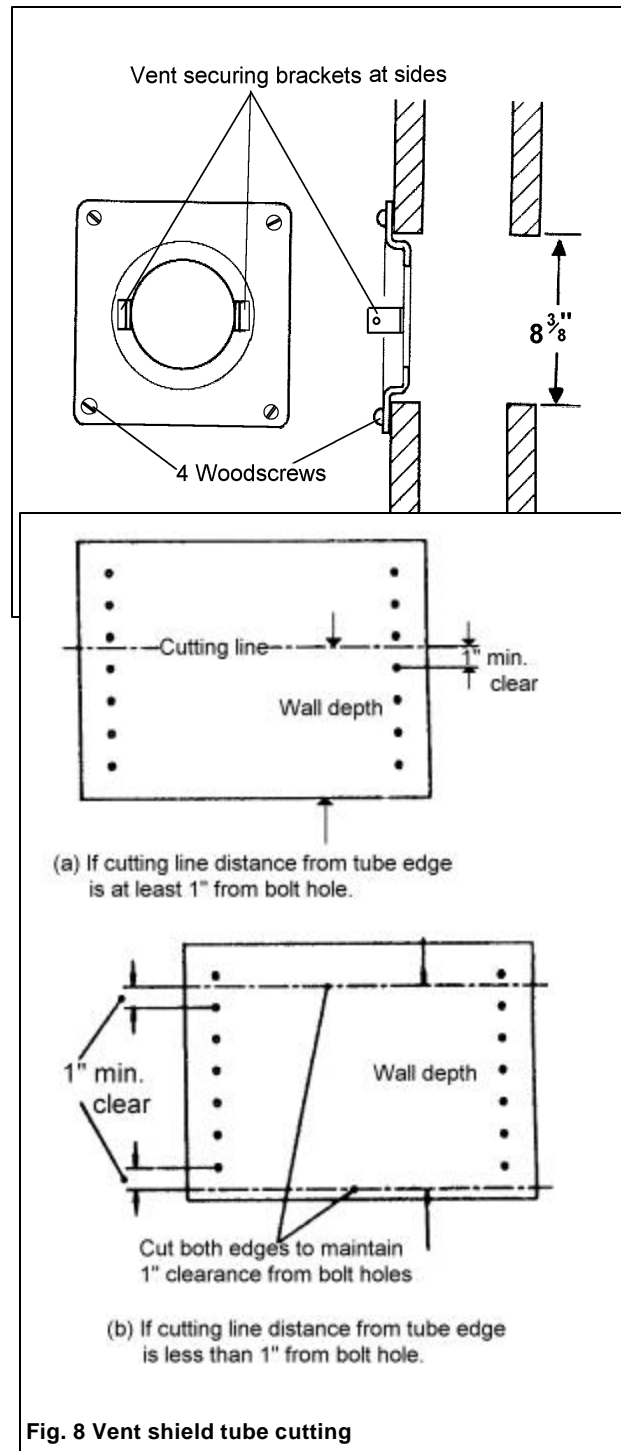
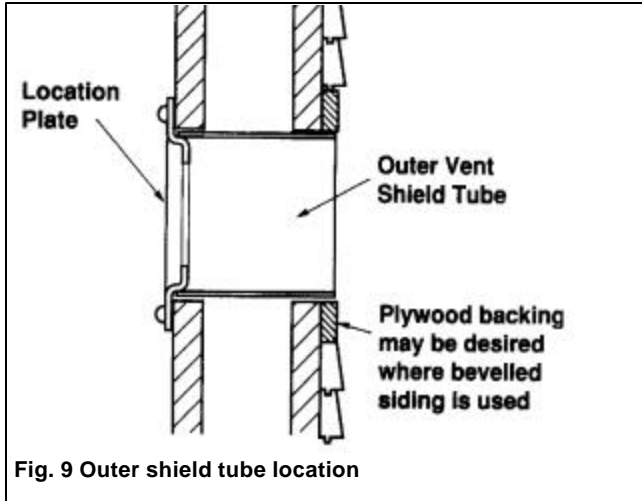

Fig. 8 Vent shield tube cutting

- 7.10 Form the shield into a tube with the holes aligned. Fasten using the #10 bolts and nuts provided with the bolt heads outside.

- 7.11** Insert the shield tube into the wall from the outside wall. Push the tube firmly in so that it locates fully over the dished diameter of the inside wall plate. Trim the tube if necessary (see figure 9). The outside end of the tube can be temporarily held in place by inserting wedges of cardboard, wood, etc. round the wall hole to prevent tilting.



8. GAS SUPPLY INSTALLATION

- 8.1** Route the gas supply line to the appliance inlet connection point (see figure 2).
Note: Pressure testing the line for leaks may need to be performed before the line is connected to the appliance - see section 12.
- 8.2** Gas connection to the appliance is 3/8"NPT.
- 8.3** Use only new black iron or steel pipes or copper tubing if acceptable - check local codes. *Note that in USA copper tubing must be internally tinned for protection against sulfur compounds.*
- 8.4** Unions in gas lines should be of ground joint type.
- 8.5** The gas supply line must be sized and installed to provide a supply of gas sufficient to meet the maximum demand of the appliance without undue loss of pressure.
- 8.6** Sealants used must be resistant to the action of all gas constituents including LP gas. Sealants should be applied lightly to male threads to ensure excess sealant does not enter gas lines.
- 8.7** The supply line should include a manual shut-off valve to allow the appliance to be disconnected for servicing.
- 8.8** A plugged 1/8"NPT tapping must be installed in the line. The tapping must be accessible for test gauge connection and be immediately upstream of the gas supply connection to the appliance.

9. BASE & MAIN APPLIANCE INSTALLATION

9.1 PEDESTAL BASE

- 9.1.1** Detach the pedestal front panel by removing two screws.
- 9.1.2** Place the pedestal in position (see figure 10). The bottom rear of the pedestal must be at least 1/2" from the back wall to allow room for the stove top overhang.
- 9.1.3** Mark the floor with the floor fixing positions through the holes in the pedestal (see figure 10).
- 9.1.4** Remove the pedestal. Drill the floor at the marked positions and fit plugs if necessary.
- 9.1.5** For easier fixing, fit the two woodscrews supplied into the floor partially leaving a space between the screw heads and the floor. The pedestal has two "keyhole" openings in its bottom channels. Place the pedestal back in position by dropping it to locate the screws in the wide holes of the keyholes and then sliding the pedestal back to locate the screws in the narrow slots of the keyholes. Tighten the screws.
- 9.1.6** Fit the inlet elbow to the supply pipe.
- Note: If the optional circulating fan kit is intended to be installed, it will be easiest to fit it at this stage**
- 9.1.7** Place the main appliance unit over the pedestal, align the 4 fixing holes (2 at each side) and secure the unit to the pedestal with 4 machine screws.

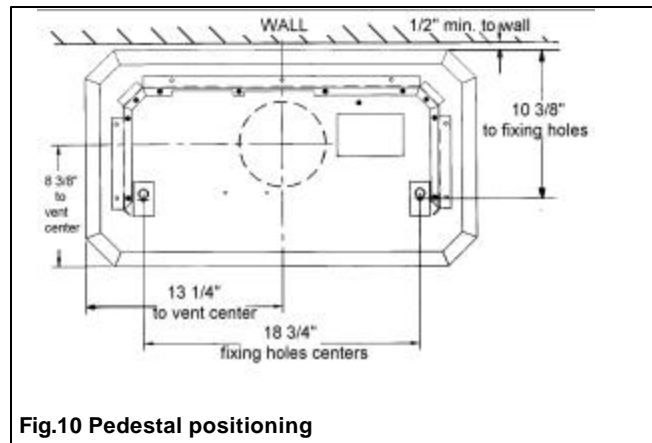

9.2 BASE WITH LEGS

- 9.2.1 Detach the door retaining bracket (located near the rear right corner of the appliance main unit) by removing two screws (see figure 11).
- 9.2.2 Swing the bottom of the door forward to release the bottom pin from the slot in the case and lift the door clear (see figure 11).

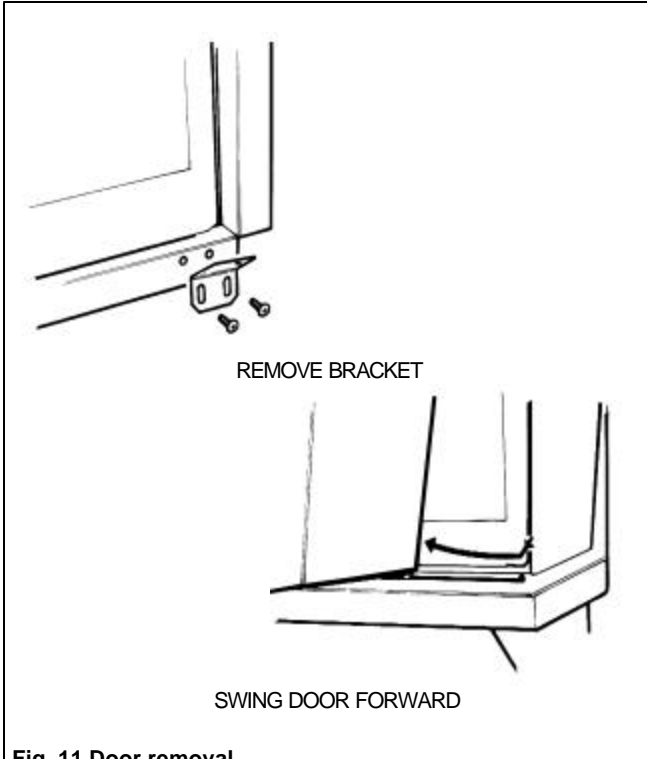

Fig. 11 Door removal

- 9.2.3 Place the base in position (see figure 12). The rear of the base may touch the wall but a slight gap is advisable to stop the stove top from scraping the wall when placing it on the base.
- 9.2.4 Mark the floor fixing positions through the holes in the rear feet.
- 9.2.5 Remove the base. Drill the floor at the marked

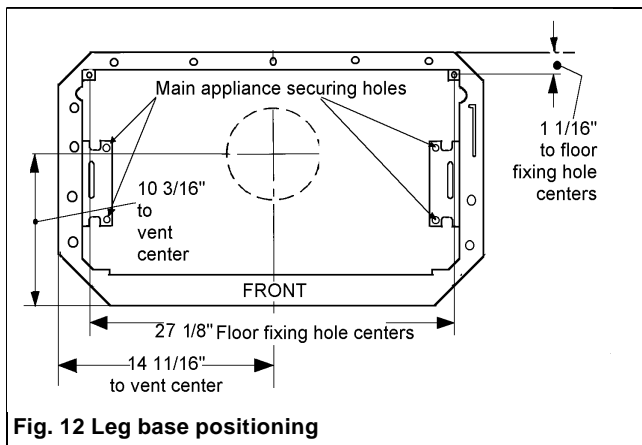

Fig. 12 Leg base positioning

positions and fit plugs if necessary.

- 9.2.6 Replace the base. Fit woodscrews through the rear feet and tighten.
- 9.2.7 Fit the inlet elbow to the supply pipe.

- 9.2.8 Place the main appliance unit over the base, align the securing holes (see figure 12). Secure with 4 machine screws.
- 9.2.9 Replace the door as follows:
 - 9.2.9.1 Locate the hinge pin at top of the door into the hole at the top of the door aperture (see figure 13).
 - 9.2.9.2 Locate the hinge pin at bottom of the door into the slot in the base. Swing the bottom of the door part way to the back. A new door retaining bracket is supplied with the leg and facia kit. Hold this bracket under the bottom of the base side. Position it with the two holes at the bottom and locate the single hole over the bottom door hinge pin (see figure 13).
 - 9.2.9.3 While keeping the bracket located to the hinge pin, swing the door and bracket fully backwards. Align the two holes in the bracket with the two holes in the base side and fix with the two tapping screws

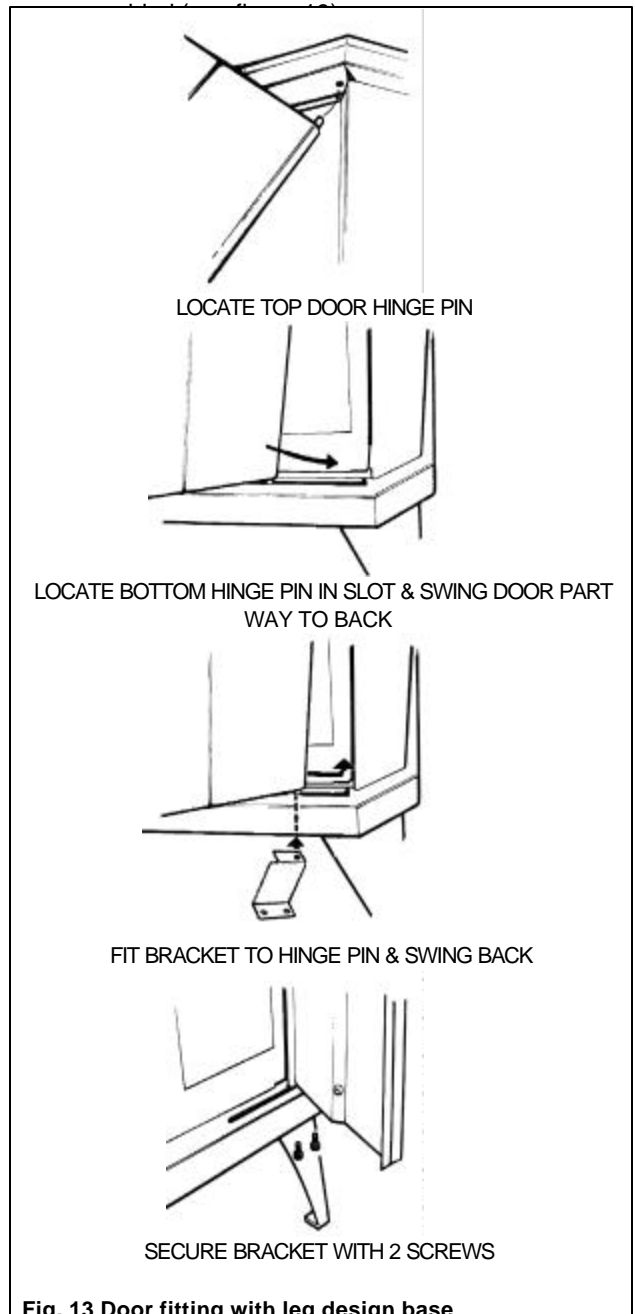

Fig. 13 Door fitting with leg design base

10. VENT UNIT INSTALLATION

- 10.1 If using any optional vent extension kits #905VEK, cut to the required sizes - see venting graph figure 1.
- 10.2 Identify the appliance top decorative collar. The collars have identification labels. Remove the label. Place the collar over the vertical section of the elbow or vertical extension. Locate the elbow unit or vertical extension fully over the appliance vent ducts.
- 10.3 If any vertical extension units are installed, locate the elbow unit fully over the top of the extension.
- 10.4 Rotate the elbow until it is in direct line with the wall opening.
- 10.5 If a horizontal extension is required, loosely fit a joint masking collar (supplied with the kit) over the extension. Fit the extension fully to the end of the elbow. If necessary, temporarily support it.
- 10.6 Loosely fit the joint masking collar (supplied with the appliance vent unit) over the free end of the horizontal length of the vent. Loosely fit the decorative wall collar over the horizontal length of the vent with the central dished area projecting into the room.
- 10.7 Measure the distance from the elbow or horizontal extension to the wall allowing for the amount of overlap where the elbow or extension enters the terminal unit (figure 14 dimension "A").
- 10.8 Calculate the total length of terminal required. This length is:- Elbow or extension to wall (figure 14 dimension "A") + Wall thickness (figure 14 dimension "B") + $3\frac{5}{8}$ " (terminal length outside wall).

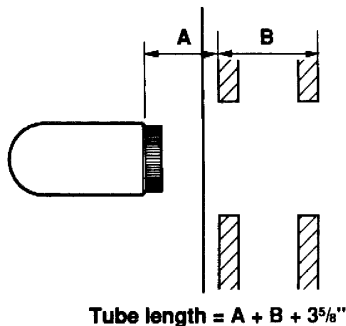

Fig.14 Vent terminal length

- 10.9 Mark the vent terminal at the length calculated **measuring from the outside end of the vent cap**. Insert the Styrofoam support ring and push it as close to the marked position as possible. Cut off the vent tubes squarely at the marked position. **Make sure that all Styrofoam is removed from the vent unit after cutting.**
- 10.10 Fit the vent terminal unit through the wall from the outside. Locate the inside end fully over the elbow or horizontal extension.. **Make sure that the seam on the outer tube is not at the bottom.**

- 10.11 Place the remaining wall plate over the outside wall end of the terminal with the dished projection facing inside. Push the plate up to the wall so that the dished projection locates inside the vent shield tube (see fig. 15). Remove any temporary wedges. If possible while still maintaining a sound connection to the appliance, slope the terminal very slightly down towards the outside so that any rain will run away from the appliance. **The terminal should never slope down into the room. This could cause water to accumulate in the appliance.** Mark the wall plate fixing holes on the wall. Remove the plate.

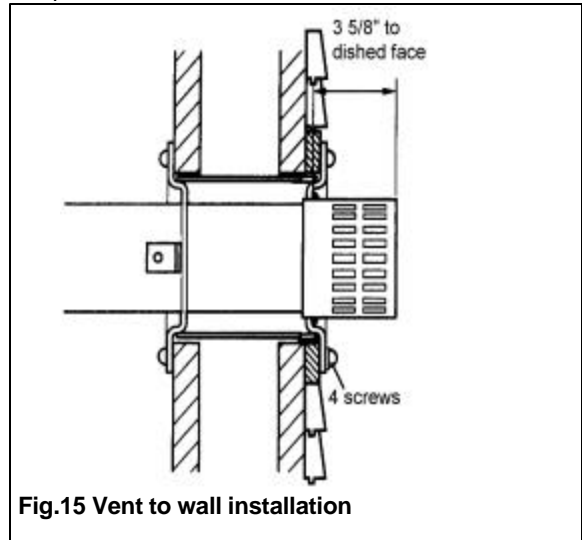
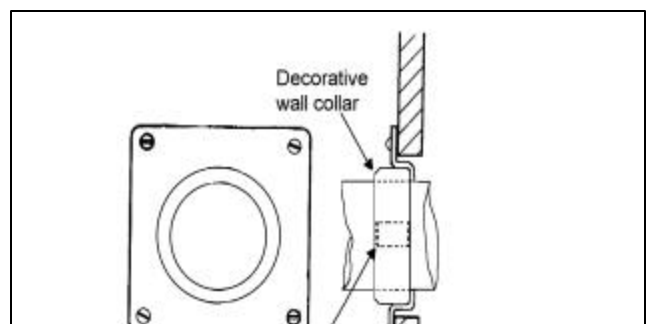

Fig.15 Vent to wall installation

- 10.12 Drill the fixing holes in the wall and insert plugs if necessary.
- 10.13 Replace the wall plate locating it firmly inside the shield tube. Make sure that the slots in the terminal end cap are outside the wall plate (see figure 15).
- 10.14 Line up the screw holes. Start the mounting screws. Apply a clear silicone rubber sealant under the edges of the wall plate and tighten the screws. Apply a bead of silicone sealant around the vent tube where it exits the wall plate (see figure 15).
- 10.15 When the terminal is properly located, secure it at the inside wall end by drilling into the terminal outer tube through the holes in the two vent securing brackets and securing with two #6 tapping screws provided. **Make sure that the drill does not penetrate the inner vent tube.**
- 10.16 Remove the backing paper from the adhesive pads on the wall plate vent securing brackets. Push the decorative wall collar firmly inside the dished center of the wall plate onto the adhesive pads (see fig. 16).



10.17 Place a piece of card, thick paper, etc. over the top of the appliance to protect it. Secure the elbow or extension at the appliance ducts by drilling and securing with two #6 tapping screws provided (Lift the decorative vent collar clear while working). See figure 17. **Make sure that the drill does not penetrate the inner vent duct.**

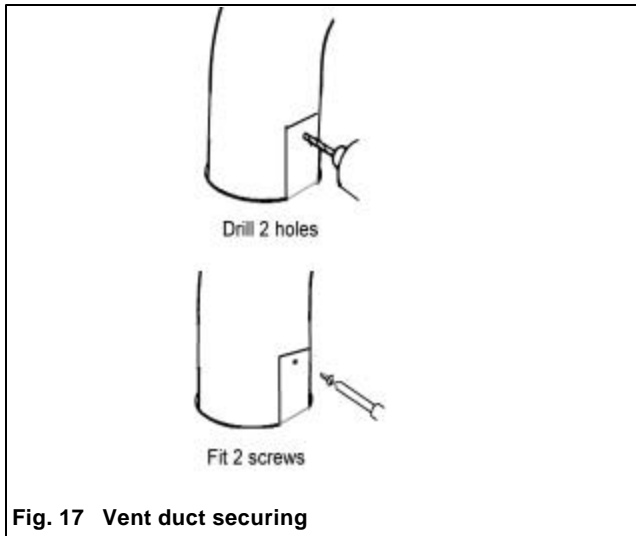

Fig. 17 Vent duct securing

10.18 Seal the joint between the elbow and the terminal with the sealing tape supplied (see figure 18).

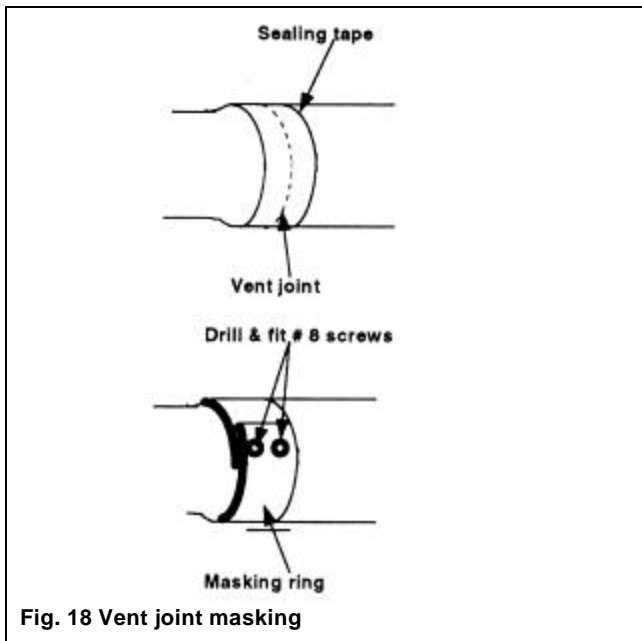

Fig. 18 Vent joint masking

10.19 Locate the masking collar over the joint so that it hides the tape. Squeeze the collar as tight as possible and align the two holes and slots in the

collar. Mark the sealing tape at the position of the holes (see figure 18).

10.20 Move the masking collar out of the way. Drill for #8 tapping screws at the marked positions. **Make sure that the drill does not penetrate the inner duct.**

10.21 Place the masking collar back in position. Squeeze as tight as possible and fix over the vent joint with two #8 tapping screws (see figure 18).

10.22 If extensions are installed, seal each extra joint with tape and cover each joint with a masking collar as described in sections 10.18 through 10.21. A length of tape and sealing collar is supplied with each kit.

11. GAS LINE CONNECTION

11.1 Open the control panel door.

11.2 Pull off the two control knobs.

11.3 Detach the control cover panel (see figure 19):-

- Remove three screws.
- Lift the panel up
- Pull the bottom front corner of the panel forward and out to clear the case and then lift clear.

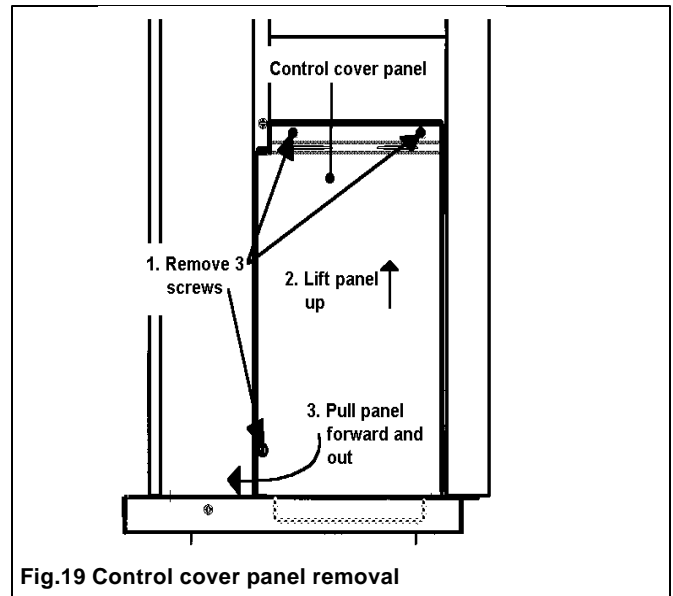
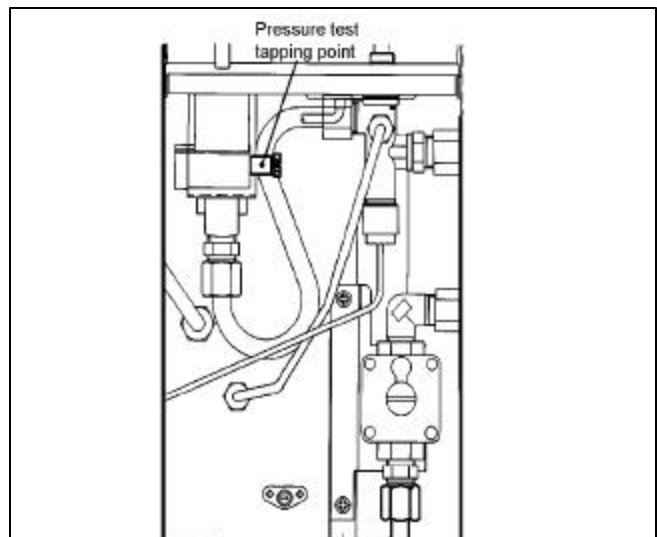

Fig.19 Control cover panel removal

11.4 Couple the gas inlet pipe to the connector below the regulator (see figure 20).



- 11.5 Connect the other end of the inlet pipe to the elbow attached to the supply line.

12. SYSTEM CHECK

- 12.1 Pressure test the supply line for leaks.
- The appliance and its individual shut-off valve must be disconnected from the gas supply piping system during any pressure testing of that system at test pressures in excess of $\frac{1}{2}$ psig (3.5kPa).
 - The appliance must be isolated from the gas supply piping system by closing its individual manual shut-off valve during any pressure testing of the gas supply piping system at test pressures equal to or less than $\frac{1}{2}$ psig (3.5kPa).
 - Failure to either disconnect or isolate the appliance during pressure testing may result in regulator or valve damage. Consult your dealer in this case.
- 12.2 The appliance is preset to give the correct input with the gas indicated on the rating plate. For input adjustment, the gas supply pressure to the appliance inlet must be within the limits stated in Section 2.3 of this manual.
- 12.3 The burner manifold pressure is controlled by a built-in non-adjustable regulator. The correct pressure range is shown in the table in section 2.3 of this manual. The manifold pressure should be checked at the pressure test point which is located on the thermostat unit (see figure 17). The pressure check should be made with the appliance burning, the gas control set at "On" and the thermostat control set at "Full". (Temporarily refit the control knobs for checking.)
- 12.4 All piping and connections must be tested for leaks after installation or servicing. All leaks must be corrected immediately.
- When testing for leaks:
- Make sure that the appliance gas control knob is at the "Off" position.
 - Open the manual shut-off valve.
 - Test for leaks by applying a liquid detergent or soap solution to all joints. Bubbles forming indicate a gas leak. **Never use an open flame to check for leaks.**
 - Correct any leak detected immediately.

13. PRESSURE RELIEF SYSTEM CHECK

The appliance is fitted with a pressure relief system. Its purpose is to allow the safe release of pressure in the unlikely event of a build up of gas in the fire box before ignition takes place.

Relief is achieved by the gas pressure pushing open the two spring loaded plates under the fire box below the front burner. This allows some gas to escape safely. The plates will then return to their closed position (see figure 21).

14. AERATION SETTING CHECK

On natural gas and propane appliances both front and rear burners are equipped with adjustable aeration shutters to control primary aeration.

For the natural gas appliance both front and rear burner shutters are set fully open.

For the propane appliance the front burner shutter is set fully open and the rear shutter partially closed.

For the majority of installations the above settings will be correct and the shutters should not be adjusted. In a few instances performance may be improved by adjusting the aeration. This will not be able to be properly determined, however, until the appliance is operated with the logs and window installed.

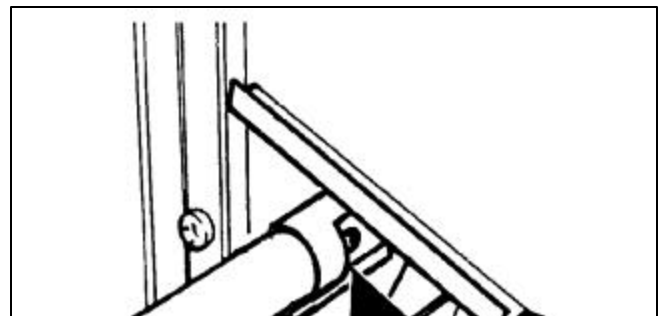
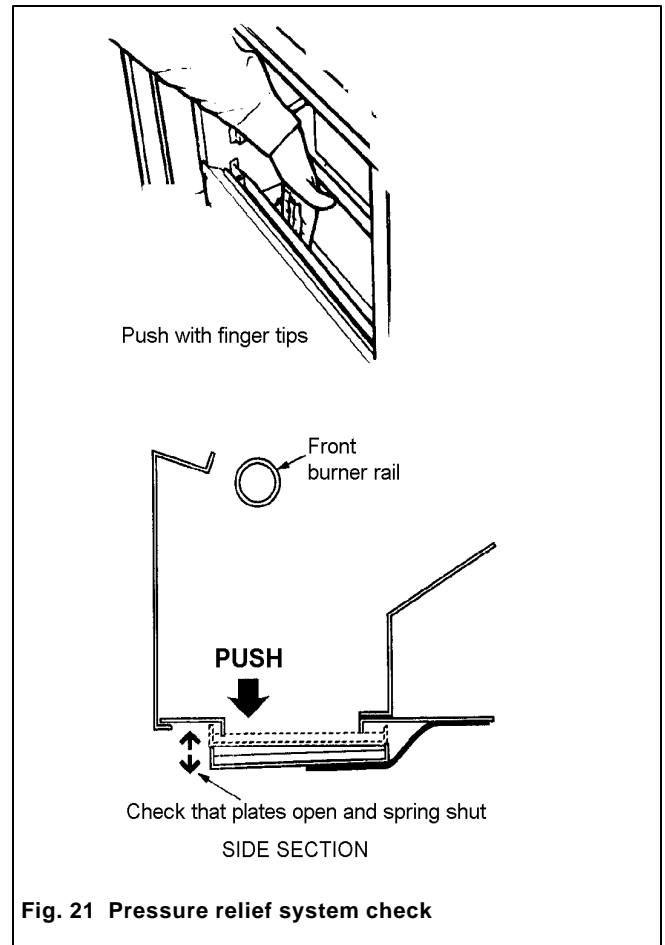

15. CERAMIC FUEL BED ASSEMBLY

- 15.1** Place the ceramic back wall in position centrally at the back of the firebox. It must rest on the metal ledge at the back of the firebox (see figure 23).

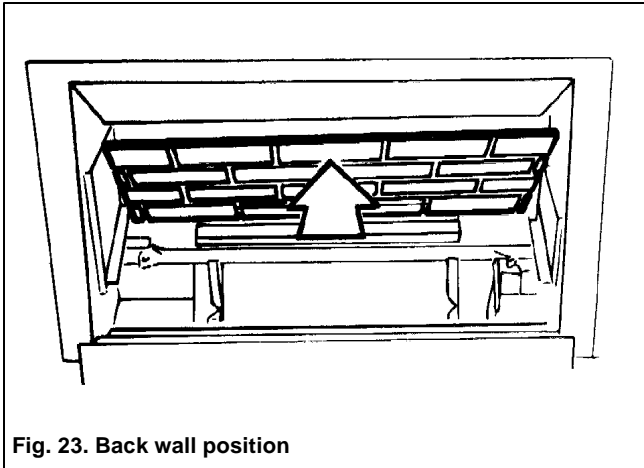

- 15.2** Place the ceramic side walls in position at the sides of the firebox. The sides are left and right handed. The sides should locate in the sloping channels near the bottom of the firebox sides and in the gap between each side of the firebox and the black top baffle (see figure 24).

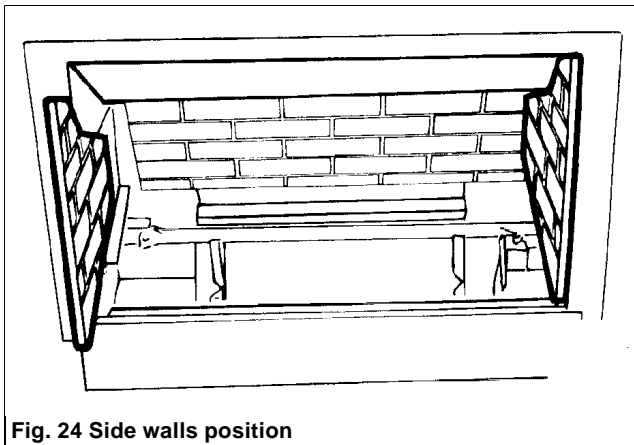

- 15.3** Place the rear log in the retaining cradle behind the rear burner tube with its back against the back wall. Center the log so that the gap to the side wall is the same at each side (see figure 25).

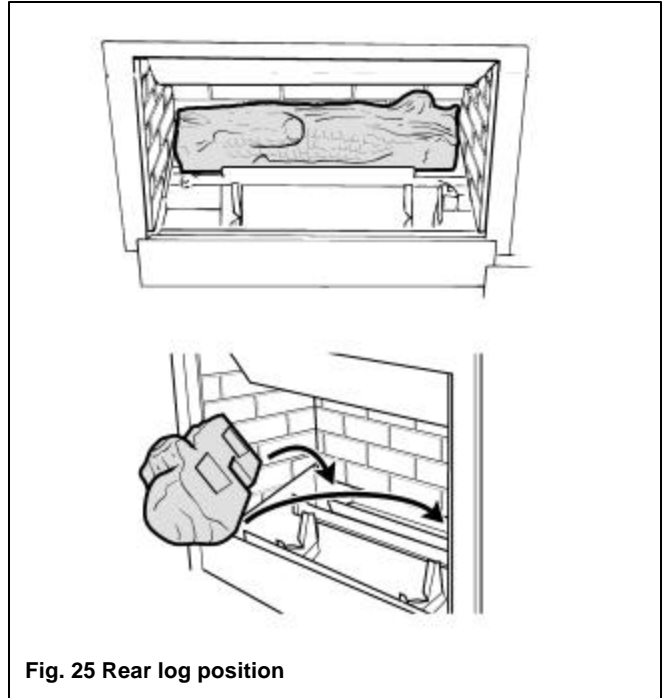

- 15.4** Place the centre log on the retaining cradles between the rear and front burner tubes. Center the log so that the gap to the side wall is the same at each side (see figure 26).

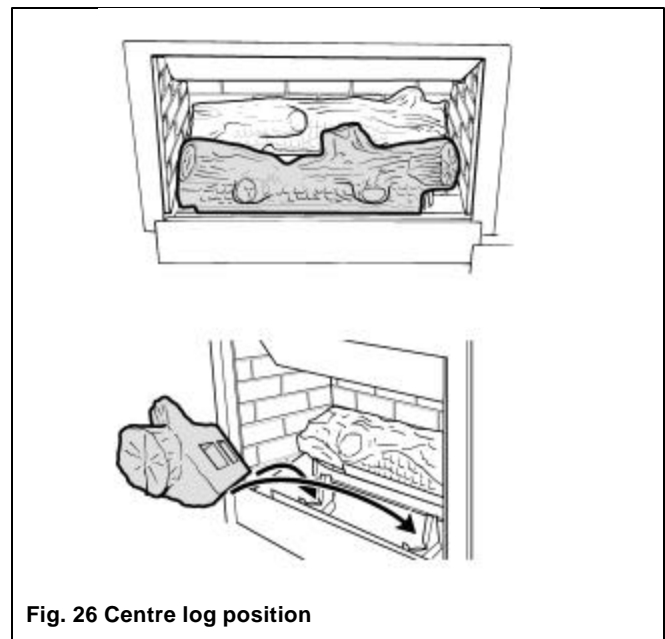

- 15.5 Place the two front logs in position on the front rail of the firebox. It may be necessary to raise the center log slightly in order to fit the left-hand front log.

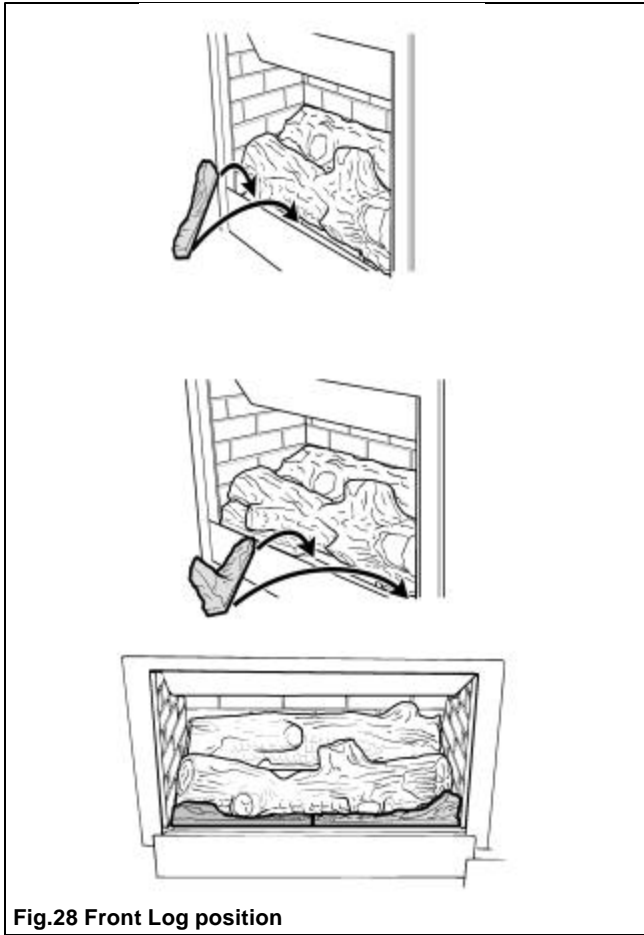

Fig.28 Front Log position

16. CONTROLS OPERATION CHECK

- 16.1 Refit the control cover panel. Refit the two control knobs
- 16.2 If installed with a pedestal base, refit the pedestal front panel.
- 16.3 If installed with a traditional design front fascia, fit the window frame top cover (supplied in the pack) over the top of the window frame to hide the bare metal (see figure 29).

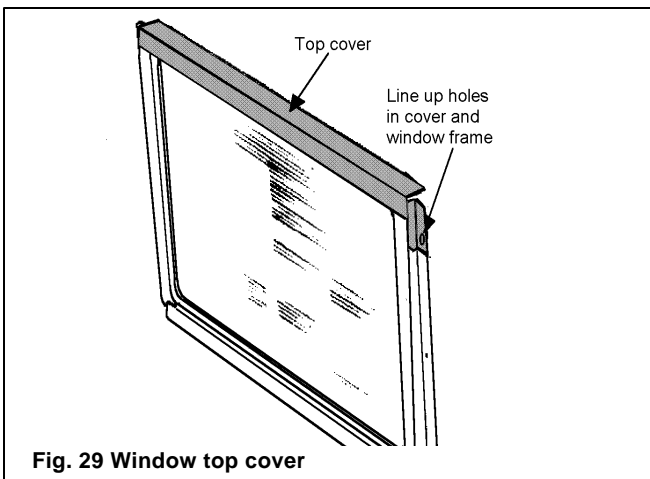

Fig. 29 Window top cover

- 16.4 Refit the window (with top cover if applicable).
- Hook the top of the window frame over the firebox top front edge.
 - Swing the window down over the bottom center locating stud.
 - Secure the window unit in place by refitting the knurled nut and 8 knurled screws at the sides and bottom of the window frame.
 - Check ignition, gas control valve and thermostat settings as described in the lighting instructions section further on in this manual.

17. AERATION ADJUSTMENT

As described in section 14, the burners have adjustable aeration. For the great majority of installations, no adjustment will be necessary. However, in a few instances performance may be improved by adjusting the aeration. Aeration is adjusted by sliding the shutter to the left or right. Evaluate the aeration only after the unit has warmed up (approximately 15 minutes).

Increasing aeration (by sliding the shutter to the left) will cause the flame to appear more transparent and blue making the logs glow more.

Decreasing aeration (by sliding the shutter to the right) will cause the flames to appear more yellow or orange making the logs glow less. **Too little aeration may result in black carbon forming and dropping into the firebox.**

18. FACIA INSTALLATION

18.1 Contemporary front only: Fit the ashlip to the fascia unit with 4 screws (see figure 30).

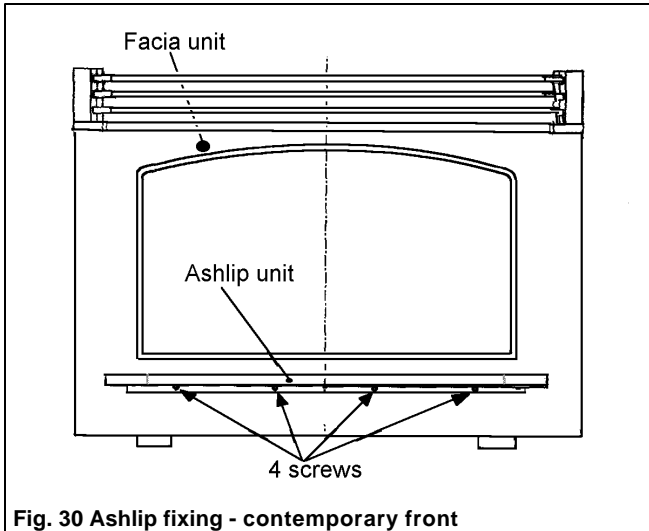

Fig. 30 Ashlip fixing - contemporary front

18.2 Locate the fascia unit to the appliance front - see figure 31. Locate at the top corners and at the bottom. We suggest the following order:

- 1) Angle the top of the fascia against the upper part of the appliance front.
- 2) Push the fascia up between the appliance front and the appliance top.
- 3) Push the lower part of the fascia against the appliance front.
- 4) Lower the fascia on to the locations.

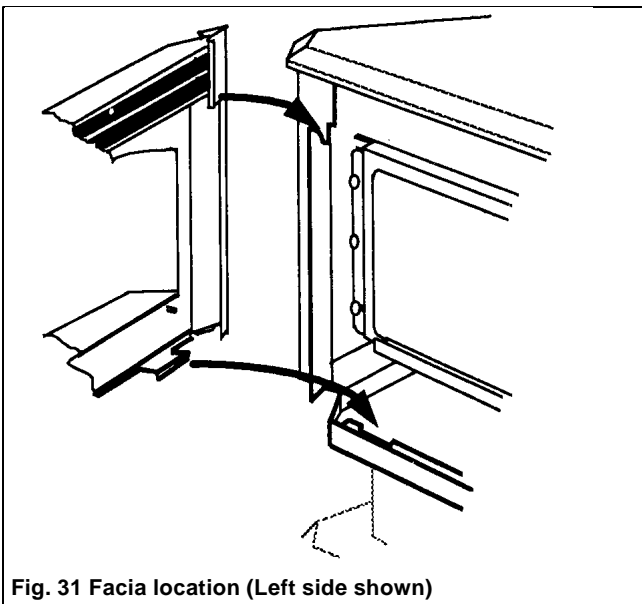

Fig. 31 Fascia location (Left side shown)

19. FINAL CHECK

- 19.1** Recheck gas control and thermostat operation.
- 19.2** Instruct the owner how to operate the appliance.
- 19.3** Warn that *if the ceramic window unit is damaged, the appliance must be turned off immediately and not used until the window is replaced.*
- 19.4** Advise that, if necessary, the window may be removed when the appliance is shut off and cold to clean the inside or reset the logs if disturbed. Stress that the window must be replaced securely before operating the appliance.
- 19.5** Recommend that the appliance is inspected and, if necessary, serviced at least once a year.
- 19.6** Point out the location of the supply shut off valve and its operation.
- 19.7** Point out the location of the vent terminal. Advise that, for safe and efficient operation, no objects should be placed within 2 feet (60cm) of the vent terminal.
- 19.8** Close the control panel door.

20. OPERATING PROCEDURE

The operating instructions are also inside the control panel door.

- 20.1** For your safety this appliance is fitted with a flame supervision device which will shut off the gas supply if, for any reason, the pilot flames go out. This device incorporates a fixed probe which senses the heat from the pilot flame. If the probe is cool, the device will prevent any gas flow unless the gas control knob is kept pushed in between the "Off" and "Ign" positions. See full lighting instructions on next page.
- 20.2** Open the control panel door at right side of the stove for access to the controls. Close the door when you have finished operation the controls.
- 20.3 The Valor Comfostat™ Temperature control system**
Conventional thermostats regulate the temperature by shutting the burners off when the temperature reaches its upper limit. This gives stop-go heat, unnaturally varying flames and impaired efficiency (like a car in city traffic). The Comfostat™ system controls the temperature by gradually lowering or raising the fire. This maintains room comfort by providing steadier heat and a more natural looking regulation of the flames. The room temperature will be maintained at the desired level for any setting up to just short of the "Full" position. The "Full" position is an override which will keep the fire fully on all the time and is not affected by room temperature.
- 20.4** When first turned on, the decorative flames will appear predominantly blue. After approximately 15 minutes the flames will turn yellow.

21. LIGHTING WITH LONG MATCH

In the unlikely event of failure to create an ignition spark using the control knob, the stove can be lit as follows:

- 21.1** Lift off the front fascia
21.2 Remove the window unit
21.3 Open the control panel door.
21.4 Insert a long burning match at the pilot.
21.5 Operate the controls as described in the lighting instructions.
21.6 Make sure that the pilot flame is stable.
21.7 Replace the window unit securely **before turning the controls to any position other than pilot.**
21.8 Replace the fascia.
21.9 Select the burner setting.
21.10 Close the control panel door.

22. CLEANING

- 22.1** Only clean when the appliance is cold.
22.2 Normally, the appliance should only need dusting. Any stains on the ceramic glass window can be removed with a non-abrasive cleaner. **Never use abrasive cleaners on the glass.**
22.3 Dust, etc. can be brushed from the logs after detaching the front fascia and window. If you are removing the logs, we suggest that they are

removed in the reverse order to that shown in the fuel bed assembly instructions.

- 22.4** Always replace the window and fascia after any cleaning as shown in the installation section of these instructions.
22.5 Discoloration of the metal firebox is normal when used.

23. CHECKS

- 23.1** A periodic visual check of the pilot and burner flames should be made (see figures 32 & 33).

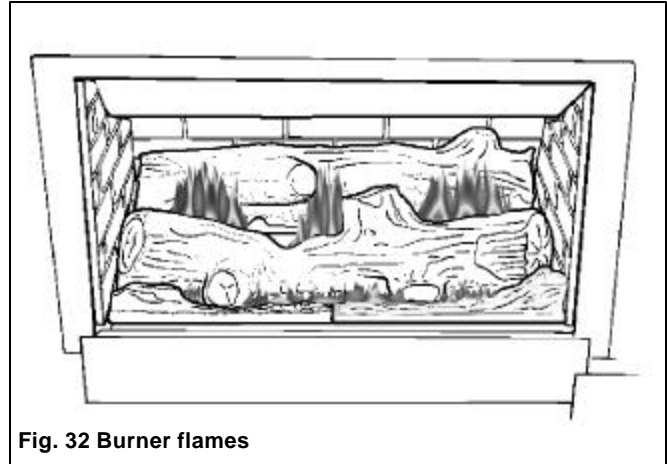

Fig. 32 Burner flames

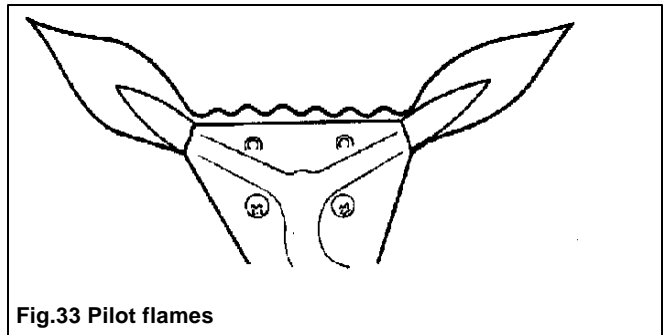

Fig.33 Pilot flames

- 23.2** The appliance area must always be kept clear and free from combustible materials, gasoline and other flammable vapors and liquids.
23.3 Inspect the vent terminal outdoors regularly to make sure that it is not obstructed by dirt, snow, insects, leaves, etc.
23.4 Examine the whole vent system regularly. We recommend annually.

24. SERVICING

If you require any attention to your appliance, contact your supplier quoting the model number. It will be helpful if the appliance serial number can also be quoted. This is on the rating plate visible when the control panel door is opened. The repair parts are shown in the separate repair parts leaflet. Please always quote part number and description when requesting spare parts.

FOR YOUR SAFETY READ BEFORE LIGHTING

WARNING: If you do not follow these instructions exactly, a fire or explosion may result causing property damage, personal injury or loss of life.

- A. This appliance has a pilot which must be lighted by hand. When lighting the pilot, follow these instructions exactly.
- B. **BEFORE LIGHTING** smell all around the appliance area for gas. Be sure to smell next to the floor because some gas is heavier than air and will settle on the floor.
WHAT TO DO IF YOU SMELL GAS
 - Do not try to light any appliance.
 - Do not touch any electric switch; do not use any phone in your building.
 - Immediately call your gas supplier from a neighbor's phone. Follow the gas supplier's instructions.
 - If you cannot reach your gas supplier, call the fire department.
- C. Use only your hand to push in or turn the gas control knob. Never use tools. If the knob will not push in or turn by hand, don't try to repair it, call a qualified service technician. Force or attempted repair may result in a fire or explosion.
- D. Do not use this appliance if any part has been under water. Immediately call a qualified service technician to inspect the appliance and to replace any part of the control system and any gas control which has been under water.
- E. During extreme weather conditions, make sure that the vent outlet is free of ice and snow before attempting to light.

LIGHTING INSTRUCTIONS

1. **STOP!** Read the safety information above on this page.

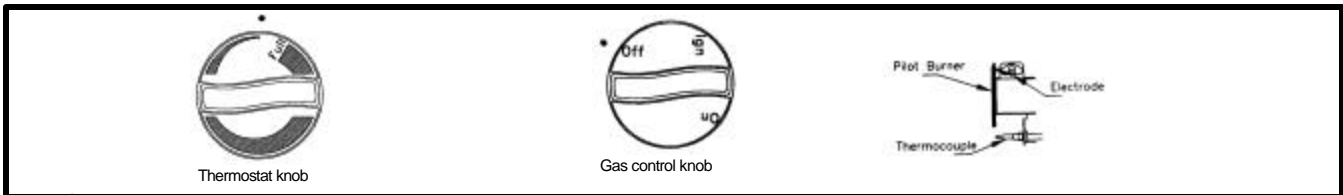

2. Set the thermostat to its lowest setting.
3. Turn the gas control knob clockwise to "Off".
Note: Knob cannot be turned to "Off" unless it is pushed in partially. Do not force.
4. Wait five (5) minutes to clear out any gas. If you then smell any gas, **STOP!** Follow "B" in the safety information above on this label. If you don't smell gas, go to next step.
5. Find the pilot. It is at the right side of the firebox.
6. Push in and turn the gas control knob counter-clockwise until resistance is felt. Keep pushed in at this position for a few seconds to allow gas to flow.
7. Keep knob pushed in and turn to "Ign" to light pilot. While turning to this position ignition sparks will be activated twice. Hold knob in for a further 5 seconds then release. The knob should pop back up. The pilot should remain lit. If pilot goes out repeat steps 3 through 7. If pilot does not light at all during a few attempts, try lighting with a long match as described below.
 - If pilot lights but will not stay lit after several tries, turn the gas control knob to "Off" and call your service technician or gas supplier.
8. When pilot is lit, partially depress the gas control knob and turn counterclockwise to "On".
 - Do not leave knob set between "Ign" and "On".
9. Set thermostat to desired setting.
10. Close control access door.
Match lighting: After removing the window unit, apply a long match to the pilot while the gas control knob is pushed in at the "Ign" position - See previous page for full details.
 - Always replace the window unit after match lighting the pilot.
 - The gas control knob should always pop up when released. If it does not, stop and immediately call your service technician or gas supplier.

TO TURN OFF GAS TO APPLIANCE

1. Set the thermostat to lowest setting.
2. Push in the gas control knob and turn clockwise to "Off". Do not force.
3. Close control access door.

Manufactured by

Valor HEATING

BIRMINGHAM, ENGLAND

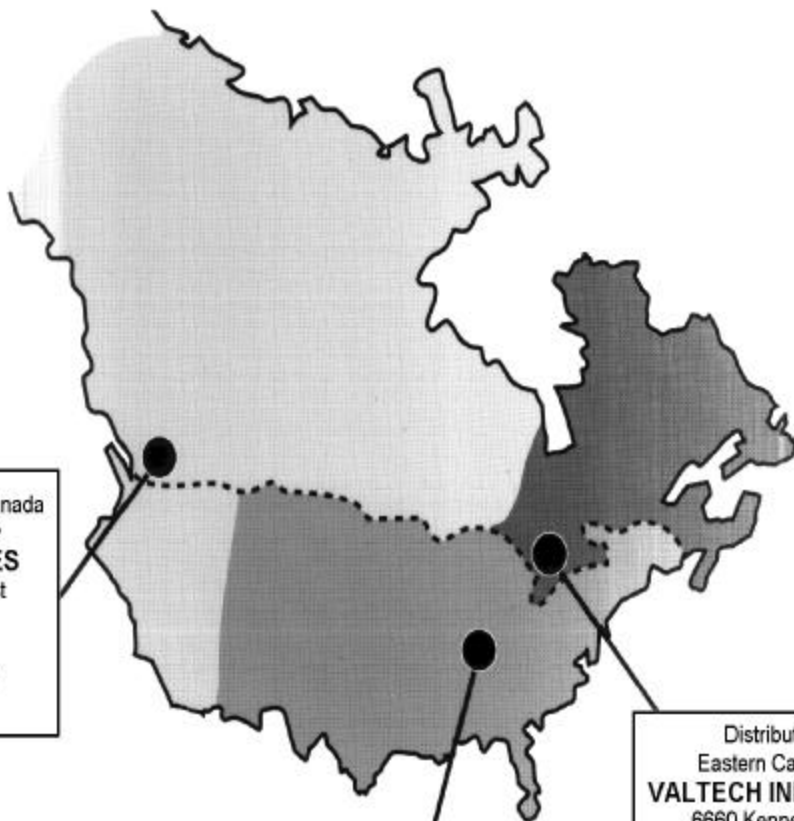

Distributed in Western Canada
and Western USA by
MILES INDUSTRIES
829 Third Street West
North Vancouver
B.C. V7P 3K7
Ph. (604) 984-3496
Fax (604) 984-0246

Distributed in
Eastern Canada by
VALTECH INDUSTRIES
6660 Kennedy Road
Mississauga
Ontario L5T 2M9
Ph. (905) 795-0333
Fax (905) 795-0336

Distributed in Central and
Eastern USA by
VALOR HEATING

Post Office Box 604
122A Davis Street
Portland, TN 37148
Ph. 1-800-892-8136
Fax 1-800-872-8062

Because our policy is one of constant development and improvement, details may vary slightly from those given in this publication.